

CATALOGO 2CCL



Motori Asincroni Trifasi Autofrenanti con Rotore a Gabbia

Freno in corrente continua
Serie FECCL
Costruzione Chiusa
Ventilazione esterna

Motori Asincroni Trifasi Autofrenanti con Rotore a Gabbia

**FRENO IN CORRENTE CONTINUA - SERIE FECCL - COSTRUZIONE CHIUSA - VENTILAZIONE ESTERNA -
GRANDEZZA 63 - 280T**

I motori di questa serie risultano dall'accoppiamento di un motore asincrono trifase e di un gruppo freno elettromagnetico.

Le caratteristiche di sicurezza, precisione, rapidità dell'arresto con tempo di inserzione e disinserzione dell'ordine di 5÷80 millisecondi li rendono adatti a molteplici applicazioni:

- Frenature di carichi o coppie agenti sull'albero motore.
- Frenature di masse rotanti allo scopo di eliminare tempi passivi.
- Frenature per aumentare la precisione della messa a punto.
- Frenature di parti di macchine in caso di pericolo nel rispetto della normativa antiinfortunistica.

I motori di questo catalogo sono disponibili in esecuzione UR-CSA per i mercati canadese e statunitense.

Per qualsiasi informazione o per problemi specifici contattare il nostro ufficio tecnico.

ASYNCHRONOUS THREE-PHASE BRAKE MOTORS WITH SQUIRREL CAGE ROTOR - DIRECT CURRENT BRAKE FECCL SERIES - ENCLOSED CONSTRUCTION - EXTERNAL VENTILATION - SIZES 63 - 280T

The brake-motors of the CCL series result from coupling an asynchronous three-phase motor and an electromagnetic D.C. brake unit.

Due to their reliability and operating safety, as well as their quick braking time (connection & disconnection time = 5÷80 milliseconds) they are suitable for a great variety of applications, as:

- braking of loads or torques on the driving shaft
- braking of rotary masses in order to avoid any down-times
- braking to increase the set-up precision
- braking of machine parts in case of danger, in compliance with accident prevention rules.

The motors described in this catalogue are available in UR-CSA execution for the Canadian and US markets.

For any information or special question you can apply to our technical department.

ASYNCHRON-DREHSTROM-BREMSMOTOREN MIT KÄFIGLÄUFER - GLEICHSTROMBREMSE SERIE FECCL - GESCHLOSSENE AUSFÜHRUNG - AUSSENKÜHLUNG - BAUGRÖSSEN 63 - 280T

Die Motoren aus dieser Baureihe setzen sich aus einem Asynchron-Drehstrommotor und einer elektromagnetischen Bremse zusammen.

Die Sicherheit, die Genauigkeit sowie der schnelle Halt mit einer Einrück- und Ausrückzeit von 5 bis 80 Msek (Millisekunden) gewährleisten die verschiedensten Anwendung und zwar:

- Bremsung von, auf die Antriebswelle wirkenden, Lasten und Drehmomenten
- Bremsung umlaufender Massen zur Beseitigung unerwünschter Totzeiten
- Bremsung zur Optimierung der Einstellgenauigkeit
- Bremsung von Maschinenteilen in gefährlichen Situationen gemäß den geltenden Unfallverhütungsvorschriften.

Die in diesem Katalog beschriebenen Motoren sind in UR-CSA Ausführung lieferbar und für die kanadischen und US-amerikanischen Märkte bestimmt.

Für weitere Auskünfte oder spezifische Fragen wenden Sie sich bitte an unsere technische Abteilung.

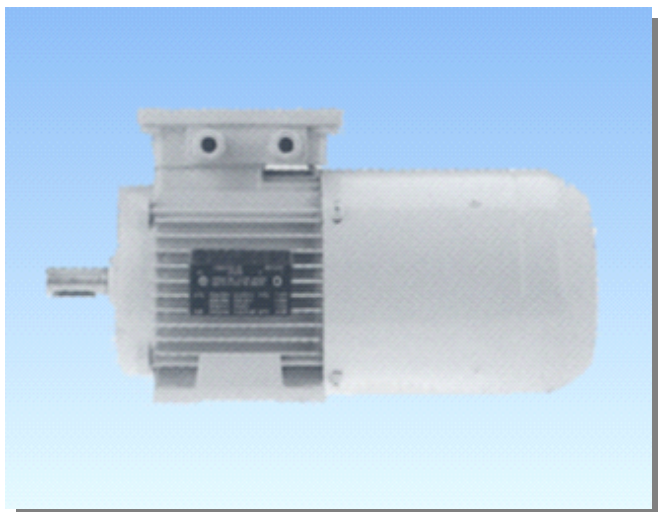

**MOTORI
ASINCRONI
TRIFASI
AUTOFRENANTI
CARATTERISTICHE TECNICHE**

FRENO IN CORRENTE CONTINUA
SERIE CCL
CON ROTORE A GABBIA
COSTRUZIONE CHIUSA
VENTILAZIONE ESTERNA
2 poli - 3000 giri/min - 50 Hz

**ASYNCHRONOUS
THREE-PHASE
BRAKE MOTORS
TECHNICAL FEATURES**

DIRECT CURRENT BRAKE
SERIES CCL
WITH SQUIRREL CAGE ROTOR
ENCLOSED CONSTRUCTION
EXTERNAL VENTILATION
2 poles - 3000 rpm - 50 Hz

**DREHSTROM-
ASYNCHRON
BREMSMOTOREN
TECHNISCHE DATEN**

MIT GLEICHSTROMBREMSE
SERIE CCL
GESCHLOSSENE AUSFÜHRUNG
OBERFLÄCHENKÜHLUNG
2 polig - 3000 U/min - 50 Hz

- Coppia frenante maggiorata a richiesta.
- Motor with increased braking torque on request
- Motor mit höheres Bremsmoment auf Anfrage

- ♣ A richiesta aggancio ritardato per impianti sollevamento
- ♣ On request, delayed brake cut in time for lifting equipments
- ♣ Auf Anfrage, verspätete Einschaltzeit für Hebezeuge

Suggeriamo freni a doppio disco D per impianti di sollevamento
We suggest double disk brake D for lifting equipments
Wir raten Doppelscheibebremse D für Hebezeuge an.

I motori autofrenanti hanno tolleranza $\pm 6\%$ sulla tensione di alimentazione.

Brake motors have a $\pm 6\%$ tolerance on the supply voltage.

Die Bremsmotoren haben eine $\pm 6\%$ Toleranz auf der Speisespannung.

Motore Motor type Motortype	Potenza Power Leistung kW	Velocità Speed Drehzahl r.p.m.	J Rotore J Rotor J Läufer Kg ^m ²	Rendim Efficiency Wirklungs %	Cos. FI	Corrente Current Nennstrom A	Coppia Torque Moment Nm.	Ca Cn	la In	Cmax Cn
63 FECCL	0.18	2680	0.00024	64	0.75	0.54	0.642	2.4	3.5	2.5
63 FECCL	0.25	2700	0.00024	64	0.75	0.75	0.884	2.4	3.5	2.5
71 FECCL	0.37	2800	0.00035	71	0.80	0.94	1.26	2.2	4	2.3
71 FECCL	0.55	2810	0.00052	71	0.80	1.4	1.87	2.5	4.6	2.6
80 FECCL	0.75	2820	0.00122	76	0.81	1.8	2.54	2.3	4.5	2.4
80 FECCL	1.1	2820	0.0017	76	0.81	2.6	3.73	2.3	4.8	2.4
90 S FECCL	1.5	2840	0.0012	77	0.82	3.4	5.05	2.4	4.9	2.5
90 L FECCL	2.2	2840	0.0019	77	0.82	5	7.4	2.4	4.9	2.5
100 L FECCL	3	2850	0.0032	82	0.82	6.4	10.1	2.6	6.5	2.8
100 L FECCL	4	2850	0.0042	82	0.82	8.6	13.4	2.6	6.5	2.8
112 MT FECCL	4	2860	0.0042	82	0.82	8.6	13.4	2.6	6.5	2.8
112 MT FECCL	5.5	2880	0.0055	83	0.85	11.3	18.2	2.5	7	2.8
112 M FECCL	7.5	2880	0.0075	84	0.86	15	24.7	2.5	7	3
132 S FECCL	5.5	2900	0.0090	85	0.86	10.9	18.1	2.5	7	2.8
132 S FECCL	7.5	2900	0.0113	85.5	0.86	14.7	24.7	2.5	7	2.8
132 M FECCL	9	2910	0.015	86	0.86	17.6	29.5	2.4	7	2.7
132 M FECCL	11	2910	0.017	86	0.86	21	36.1	2.4	7	2.7
132 M FECCL	15	2910	0.023	86	0.86	29	48.9	2.4	7	2.7
160 MT FECCL	11	2910	0.017	86	0.86	21	36.1	2.5	6.5	2.7
160 MT FECCL	15	2930	0.023	88	0.86	29	48.9	2.6	6.7	2.8
160 L FECCL	18.5	2940	0.043	89	0.86	35	60.1	2.6	6.9	2.8
160 L FECCL	22	2940	0.051	89	0.86	42	71.2	2.6	6.9	2.8
180 MT FECCL	22	2950	0.051	89	0.86	42	71.2	2.7	7	2.9
180 LT FECCL	25	2950	0.059	89	0.86	47	80.9	2.7	7	2.9
200 LT FECCL	30	2950	0.089	90	0.87	55	97.1	2.7	7.3	3
200 LT FECCL	37	2960	0.111	90.5	0.87	68	119	2.7	7.3	3
225 MT FECCL	45	2960	0.180	90.5	0.88	82	145	2.7	7.5	3
250 MT FECCL	55	2970	0.283	91	0.89	98	177	2.8	7.6	3
280 ST FECCL	75	2970	0.493	93.6	0.87	132	241	2.6	7.2	2.9
280 MT FECCL	90	2970	0.587	93.9	0.88	158	289	2.7	7.5	3

Motore Motor type Motortype	Freno Brake Bremsse K	Coppia freno statica Static brake torque Statischesbrems- moment Nm	Potenza Power Leistung W	J freno J brake J Bremsse kgm ²	Avviam. Starting Anlauf #	Aggancio ritardato Delayed cut-in time Verspätete Einschaltzeit msec.	Aggancio Rapido Quick cut-in time Schnelle Einschaltzeit msec.	Sgancio Cut-out time Aus Schalt zeit msec.	Press. Sonora Noise Geräusch dB(A)
63 FECCL	K 1	5	15	0.00005	3000	45	20	10	68
71 FECCL	K 2	12	20	0.00014	3000	50	30	15	69
80 FECCL	K 3	16	25	0.00021	1300	55	30	15	69
90 S FECCL	K 4	20	30	0.00039	1100	65	40	15	69
• 90 S FECCL	K 4 D	40	30	0.00078	1100	65	40	15	69
90 L FECCL	K 4	20	30	0.00039	1100	65	40	15	69
• 90 L FECCL	K 4 D	40	30	0.00078	1100	65	40	15	69
100 L FECCL	K 5	40	45	0.00104	900	75	45	20	70
• 100 L FECCL	K 6	60	50	0.00135	900	180	85	25	70
112 MT FECCL	K 5	40	45	0.00104	880	75	45	20	70
112 M FECCL	K 6	60	50	0.00135	880	180	85	25	70
132 S FECCL	K 7	90	55	0.00219	480	200	95	50	70
• 132 S FECCL	K 7 D	180	55	0.00438	480	200	95	50	70
132 M FECCL	K 7	90	55	0.00219	450	200	95	50	70
• 132 M FECCL	K 7 D	180	55	0.00438	480	200	95	50	70
160 MT FECCL	K 7 D	180	55	0.00438	350	200	95	50	70
160 L FECCL	K 8	200	60	0.00408	350	210	100	60	70
• 160 L FECCL	K 8 D	400	60	0.00816	350	210	100	60	70
180 LT FECCL	K 8 D	400	60	0.00816	100	210	100	60	70
200 LT FECCL	K 9 D	600	110	0.01830	80	230	135	75	69
225 MT FECCL	K 9 D	600	110	0.01830	80	230	135	75	69
250 MT FECCL	K 9 D	600	110	0.01830	80	230	135	75	69
280 ST FECCL	K 9 D	600	110	0.01830	80	230	135	75	69
280 MT FECCL	K 9 D	600	110	0.01830	80	230	135	75	69

**MOTORI
ASINCRONI
TRIFASI
AUTOFRENANTI
CARATTERISTICHE TECNICHE**

FRENO IN CORRENTE CONTINUA
SERIE CCL

CON ROTORE A GABBIA
COSTRUZIONE CHIUSA
VENTILAZIONE ESTERNA
4 poli - 1500 giri/min - 50 Hz

**ASYNCHRONOUS
THREE-PHASE
BRAKE MOTORS
TECHNICAL FEATURES**

DIRECT CURRENT BRAKE
SERIES CCL
WITH SQUIRREL CAGE ROTOR
ENCLOSED CONSTRUCTION
EXTERNAL VENTILATION
4 poles - 1500 rpm - 50 Hz

**DREHSTROM-
ASYNCHRON
BREMSMOTOREN
TECHNISCHE DATEN**

MIT GLEICHSTROMBREMSE
SERIE CCL
GESCHLOSSENE AUSFÜHRUNG
OBERFLÄCHENKÜHLUNG
4 polig - 1500 U/min - 50 Hz

- Coppia frenante maggiorata a richiesta.
- Motor with increased braking torque on request
- Motor mit höheres Bremsmoment auf Anfrage

- ♣ A richiesta aggancio ritardato per impianti sollevamento
- ♣ On request, delayed brake cut in time for lifting equipments
- ♣ Auf Anfrage, verspätete Einschaltzeit für Hebezeuge

Suggeriamo freni a doppio disco D per impianti di sollevamento
We suggest double disk brake D for lifting equipments
Wir raten Doppelscheibebremse D für Hebezeuge an.

I motori autofrenanti hanno tolleranza $\pm 6\%$
sulla tensione di alimentazione.

Brake motors have a $\pm 6\%$ tolerance on the
supply voltage.

Die Bremsmotoren haben eine $\pm 6\%$ Toleranz
auf der Speisespannung.

Motore Motor type Motortype	Potenza Power Leistung kW	Velocità Speed Drehzahl r.p.m.	J Rotore J Rotor J Läufer Kgm ²	Rendim Efficiency Wirklungs %	Cos. FI	Corrente Current Nennstrom A	Coppia Torque Moment Nm.	Ca Cn	la In	Cmax Cn
63 FECCL	0.13	1340	0.00024	60	0.60	0.52	0.93	2.3	3	2.3
63 FECCL	0.18	1340	0.00029	61	0.60	0.71	1.28	2.3	3	2.3
71 FECCL	0.25	1350	0.00035	68	0.65	0.82	1.77	2	3.5	2
71 FECCL	0.37	1350	0.00052	69	0.67	1.2	2.62	2	3.5	2
80 FECCL	0.55	1360	0.00122	72	0.70	1.6	3.86	2.3	4.3	2.3
80 FECCL	0.75	1360	0.0017	73	0.73	2	5.27	2.3	4.3	2.3
90 S FECCL	1.1	1380	0.0022	74	0.8	2.7	7.61	2.3	4.5	2.5
90 L FECCL	1.5	1380	0.0028	74	0.82	3.6	10.4	2.3	4.5	2.5
100 L FECCL	2.2	1410	0.0050	80	0.8	5	14.9	2	4.5	2.2
100 L FECCL	3	1410	0.006	81	0.82	6.5	20.3	2	4.5	2.2
112 MT FECCL	4	1420	0.009	83	0.82	8.5	26.9	2.4	5	2.5
132 S FECCL	5.5	1430	0.021	84	0.82	11.5	36.7	2.1	6	2.5
132 M FECCL	7.5	1430	0.028	85	0.84	15.4	50.1	2.1	6	2.5
132 M FECCL	9	1430	0.034	85	0.82	18.4	60.1	2.1	6	2.5
160 MT FECCL	11	1465	0.039	88	0.82	21.8	71.8	2.6	5.9	2.6
160 L FECCL	15	1465	0.080	88	0.83	30	97.8	2.6	6	2.6
180 MT FECCL	18.5	1470	0.098	90	0.84	36	120.2	2.5	6.5	2.8
180 LT FECCL	22	1470	0.12	90	0.84	43	143	2.5	6.5	2.8
200 LT FECCL	30	1470	0.16	91	0.86	56	194.9	2.4	6.5	2.8
225 ST FECCL	37	1480	0.31	91	0.86	69	238.8	2.6	7.1	2.9
225 MT FECCL	45	1480	0.39	91	0.86	84	290	2.6	7.1	2.9
250 MT FECCL	55	1480	0.51	92	0.86	100	355	2.5	7.3	2.9
280 ST FECCL	75	1485	1.15	93.6	0.86	134	482	2.5	7.3	2.7
280 MT FECCL	90	1485	1.31	93.9	0.86	160	579	2.6	6.7	2.7

Motore Motor type Motortype	Freno Brake Bremse K	Coppia statica freno Static brake torque Statischesbrems- moment Nm.	Potenza Power Leistung W	J freno J brake J Bremse kgm ²	Avviam. Starting Anlauf #	Aggancio ritardato Delayed cut-in time Verspätet Einschaltzeit ♣ msec.	Aggancio Rapido Quick cut-in time Schnelle Einschaltzeit msec.	Sgancio Cut-out time Aus Schalt zeit msec.	Press. Sonora Noise Geräusch dB(A)
63 FECCL	K 1	5	15	0.00005	3000	45	20	10	68
71 FECCL	K 2	12	20	0.00014	3000	50	30	15	69
80 FECCL	K 3	16	25	0.00021	1300	55	30	15	69
90 S FECCL	K 4	20	30	0.00039	1100	65	40	15	69
• 90 S FECCL	K 4 D	40	30	0.00078	1100	65	40	15	69
90 L FECCL	K 4	20	30	0.00039	1100	65	40	15	69
• 90 L FECCL	K 4 D	40	30	0.00078	1100	65	40	15	69
100 L FECCL	K 5	40	45	0.00104	900	75	45	20	70
• 100 L FECCL	K 6	60	50	0.00135	900	180	85	25	70
112 MT FECCL	K 5	40	45	0.00104	880	75	45	20	70
112 M FECCL	K 6	60	50	0.00135	880	180	85	25	70
132 S FECCL	K 7	90	55	0.00219	480	200	95	50	70
• 132 S FECCL	K 7 D	180	55	0.00438	480	200	95	50	70
132 M FECCL	K 7	90	55	0.00219	450	200	95	50	70
• 132 M FECCL	K 7 D	180	55	0.00438	480	200	95	50	70
160 MT FECCL	K 7 D	180	55	0.00438	350	200	95	50	70
160 L FECCL	K 8	200	60	0.00408	350	210	100	60	70
• 160 L FECCL	K 8 D	400	60	0.00816	350	210	100	60	70
180 LT FECCL	K 8 D	400	60	0.00816	100	210	100	60	70
200 LT FECCL	K 9 D	600	110	0.01830	80	230	135	75	69
225 ST FECCL	K 9 D	600	110	0.01830	80	230	135	75	69
225 MT FECCL	K 9 D	600	110	0.01830	80	230	135	75	69
250 MT FECCL	K 9 D	600	110	0.01830	80	230	135	75	69
280 ST FECCL	K 9 D	600	110	0.01830	80	230	135	75	69
280 MT FECCL	K 9 D	600	110	0.01830	80	230	135	75	69

MOTORI ASINCRONI TRIFASI AUTOFRENANTI CARATTERISTICHE TECNICHE

FRENO IN CORRENTE CONTINUA
SERIE CCL
CON ROTORE A GABBIA
COSTRUZIONE CHIUSA
VENTILAZIONE ESTERNA
6 poli - 1000 giri/min - 50 Hz

ASYNCHRONOUS THREE-PHASE BRAKE MOTORS TECHNICAL FEATURES

DIRECT CURRENT BRAKE
SERIES CCL
WITH SQUIRREL CAGE ROTOR
ENCLOSED CONSTRUCTION
EXTERNAL VENTILATION
6 poles - 1000 rpm - 50 Hz

DREHSTROM- ASYNCHRON- BREMSMOTOREN TECHNISCHE DATEN

MIT GLEICHSTROMBREMSE
SERIE CCL
GESCHLOSSENE AUSFÜHRUNG
OBERFLÄCHENKÜHLUNG
6 polig - 1000 U/min - 50 Hz

- Coppia frenante maggiorata a richiesta.
- Motor with increased braking torque on request
- Motor mit höheres Bremsmoment auf Anfrage

- ♣ A richiesta aggancio ritardato per impianti sollevamento
- ♣ On request, delayed brake cut in time for lifting equipments
- ♣ Auf Anfrage, verspätete Einschaltzeit für Hebezeuge

Suggeriamo freni a doppio disco D per impianti di sollevamento
We suggest double disk brake D for lifting equipments
Wir raten Doppelscheibebremse D für Hebezeuge an.

I motori autofrenanti hanno tolleranza $\pm 6\%$
sulla tensione di alimentazione.

Brake motors have a $\pm 6\%$ tolerance on the
supply voltage.

Die Bremsmotoren haben eine $\pm 6\%$ Toleranz
auf der Speisespannung.

Motore Motor type Motortype	Potenza Power Leistung kW	Velocità Speed Drehzahl r.p.m.	J Rotore J Rotor J Läufer Kgm ²	Rendim Efficiency Wirklungs %	Cos. FI	Corrente Current Nennstrom A	Coppia Torque Moment Nm.	Ca Cn	la In	Cmax Cn
63 FECCL	0.11	890	0.00039	45	0.6	0.59	1.18	1.7	2.8	1.9
71 FECCL	0.18	890	0.00105	54	0.61	0.79	1.93	1.7	2.8	1.9
71 FECCL	0.22	890	0.00129	55	0.61	0.95	2.36	1.8	2.8	2
80 FECCL	0.37	900	0.00164	66	0.71	1.1	3.93	1.8	3	2
80 FECCL	0.55	900	0.00256	69	0.71	1.6	5.84	2.05	3.5	2.2
90 S FECCL	0.75	910	0.00354	72	0.72	2.1	7.87	1.9	3.8	2.1
90 L FECCL	1.1	910	0.0051	73	0.72	3	11.5	2	4	2.2
100 L FECCL	1.5	920	0.0087	75	0.73	4	15.6	2.1	4.7	2.3
112 MT FECCL	2.2	940	0.014	78	0.75	5.4	22.4	2.2	5.5	2.5
132 S FECCL	3	950	0.023	80	0.78	6.9	30.2	2	5.6	2.3
132 M FECCL	4	950	0.031	82	0.78	9	40.2	2.3	5.8	2.6
132 M FECCL	5.5	950	0.041	83	0.78	12.3	55.3	2.3	6	2.6
160 MT FECCL	7.5	960	0.054	85	0.8	15.9	74.6	2.1	6	2.6
160 L FECCL	11	960	0.109	86	0.81	23	109	2.3	6.4	2.9
180 LT FECCL	15	970	0.141	87	0.82	30	148	2.4	7.2	3
200 LT FECCL	18.5	975	0.271	88	0.83	37	181	2.3	6.8	2.8
200 LT FECCL	22	975	0.320	88	0.83	44	216	2.3	6.8	2.8
225 MT FECCL	30	980	0.541	90	0.84	57	292	2.4	6.1	2.6
250 MT FECCL	37	980	0.752	91	0.84	70	361	2.4	6.8	2.7
280 ST FECCL	45	985	1.37	92	0.84	84	436	2.3	6.5	2.4
280 MT FECL	55	985	1.68	92.5	0.84	102	533	2.3	6.5	2.4

Motore Motor type Motortype	Freno Brake Bremsse K	Coppia Freno statica Static brake torque Statischesbrems- moment Nm	Potenza Power Leistung W	J freno J brake J Bremsse kgm ²	Avviam. Starting Anlauf #	Aggancio ritardato Delayed cut-in time Verspätete Einschaltzeit ♣ msec.	Aggancio Rapido Quick cut-in time Schnelle Einschaltzeit msec.	Sgancio Cut-out time Aus Schalt zeit msec.	Press. Sonora Noise Geräusch dB(A)
63 FECCL	K 1	5	15	0.00005	3000	45	20	10	68
71 FECCL	K 2	12	20	0.00014	3000	50	30	15	69
80 FECCL	K 3	16	25	0.00021	1300	55	30	15	69
90 S FECCL	K 4	20	30	0.00039	1100	65	40	15	69
• 90 S FECCL	K 4 D	40	30	0.00078	1100	65	40	15	69
90 L FECCL	K 4	20	30	0.00039	1100	65	40	15	69
• 90 L FECCL	K 4 D	40	30	0.00078	1100	65	40	15	69
100 L FECCL	K 5	40	45	0.00104	900	75	45	20	70
• 100 L FECCL	K 6	60	50	0.00135	900	180	85	25	70
112 MT FECCL	K 5	40	45	0.00104	880	75	45	20	70
112 M FECCL	K 6	60	50	0.00135	880	180	85	25	70
132 S FECCL	K 7	90	55	0.00219	480	200	95	50	70
• 132 S FECCL	K 7 D	180	55	0.00438	480	200	95	50	70
132 M FECCL	K 7	90	55	0.00219	450	200	95	50	70
• 132 M FECCL	K 7 D	180	55	0.00438	480	200	95	50	70
160 MT FECCL	K 7 D	180	55	0.00438	350	200	95	50	70
160 L FECCL	K 8	200	60	0.00408	350	210	100	60	70
• 160 L FECCL	K 8 D	400	60	0.00816	350	210	100	60	70
180 LT FECCL	K 8 D	400	60	0.00816	100	210	100	60	70
200 LT FECCL	K 9 D	600	110	0.01830	80	230	135	75	69
225 MT FECCL	K 9 D	600	110	0.01830	80	230	135	75	69
250 MT FECCL	K 9 D	600	110	0.01830	80	230	135	75	69
280 ST FECCL	K 9 D	600	110	0.01830	80	230	135	75	69
280 MT FECCL	K 9 D	600	110	0.01830	80	230	135	75	69

MOTORI ASINCRONI TRIFASI AUTOFRENANTI CARATTERISTICHE TECNICHE

FRENO IN CORRENTE CONTINUA
SERIE CCL
CON ROTORE A GABBIA
COSTRUZIONE CHIUSA
VENTILAZIONE ESTERNA
8 poli - 750 giri/min - 50 Hz

ASYNCHRONOUS THREE-PHASE BRAKE MOTORS TECHNICAL FEATURES

DIRECT CURRENT BRAKE
SERIES CCL
WITH SQUIRREL CAGE ROTOR
ENCLOSED CONSTRUCTION
EXTERNAL VENTILATION
8 poles - 750 rpm - 50 Hz

DREHSTROM- ASYNCHRON- BREMSMOTOREN TECHNISCHE DATEN

MIT GLEICHSTROMBREMSE
SERIE CCL
GESCHLOSSENE AUSFÜHRUNG
OBERFLÄCHENKÜHLUNG
8 polig - 750 U/min - 50 Hz

- Coppia frenante maggiorata a richiesta.
- Motor with increased braking torque on request
- Motor mit höheres Bremsmoment auf Anfrage

- ♣ A richiesta aggancio ritardato per impianti sollevamento
- ♣ On request, delayed brake cut in time for lifting equipments
- ♣ Auf Anfrage, verspätete Einschaltzeit für Hebezeuge

Suggeriamo freni a doppio disco D per impianti di sollevamento
We suggest double disk brake D for lifting equipments
Wir raten Doppelscheibebremse D für Hebezeuge an.

I motori autofrenanti hanno tolleranza $\pm 6\%$
sulla tensione di alimentazione.

Brake motors have a $\pm 6\%$ tolerance on the
supply voltage.

Die Bremsmotoren haben eine $\pm 6\%$ Toleranz
auf der Speisespannung.

Motore Motor type Motortype	Potenza Power Leistung kW	Velocità Speed Drehzahl r.p.m.	J Rotore J Rotor J Läufer kgm ²	Rendim Efficiency Wirkungs %	Cos. FI	Corrente Current Nennstrom A	Coppia Torque Moment Nm.	Ca Cn	la In	Cmax Cn
63 FECCL	0.07	640	0.00039	44	0.54	0.43	1.04	1.5	2	1.5
71 FECCL	0.11	650	0.0011	44	0.56	0.65	1.6	1.6	2	1.6
71 FECCL	0.15	650	0.0013	46	0.57	0.83	2.2	1.6	2.1	1.6
80 FECCL	0.18	670	0.0016	52	0.6	0.83	2.6	1.8	3	2
80 FECCL	0.25	670	0.0026	61	0.6	1	3.6	1.8	3	2
90 S FECCL	0.37	680	0.0030	64	0.63	1.3	5.2	1.8	3.2	2
90 L FECCL	0.55	690	0.0045	67	0.63	1.9	7.6	1.8	3.4	2
100 L FECCL	0.75	690	0.0087	68	0.64	2.5	10.4	2	3.4	2.1
100 L FECCL	1.1	690	0.0109	70	0.64	3.5	15.2	2	3.4	2.1
112 MT FECCL	1.5	700	0.0141	73	0.65	4.6	20.5	1.9	3.5	2.4
132 S FECCL	2.2	705	0.0307	78	0.71	5.7	29.8	1.9	4.6	2.2
132 M FECCL	3	710	0.0409	79	0.72	7.6	40.4	1.9	5	2.3
160 MT FECCL	4	710	0.0537	80	0.73	9.9	53.8	2	5	2.1
160 M FECCL	5.5	715	0.0772	82	0.73	13	73	2	5.2	2.1
160 L FECCL	7.5	720	0.109	84	0.74	17	100	2.1	5.4	2.2
180 LT FECCL	11	730	0.154	86	0.76	24	144	2.1	5.1	2.2
200 LT FECCL	15	730	0.345	87	0.76	33	196	2.1	5.4	2.3
225 ST FECCL	18.5	730	0.505	88	0.79	38	242	2.2	5.3	2.3
250 MT FECCL	30	735	0.902	90	0.8	60	390	2.4	5.5	2.6
280 ST FECCL	37	735	1.75	90.5	0.8	74	481	2.1	5	2.3
280 MT FECCL	45	735	2.12	91	0.8	89	585	2.1	5.1	2.3

Motore Motor type Motortype	Freno Brake Brems K	Coppia statica freno Static brake torque Statisches Bremsmoment Nm	Potenza Power Leistung W	J freno J brake J Bremse kgm ²	Avviam. Starting Anlauf #	Aggancio ritardato Delayed cut-in time Verspätete Einschaltzeit ♣ msec.	Aggancio Rapido Quick cut-in time Schnelle Einschaltzeit msec.	Sgancio Cut-out time Aus Schalt zeit msec.	Press. Sonora Noise Geräusch dB(A)
63 FECCL	K 1	5	15	0.00005	3000	45	20	10	68
71 FECCL	K 2	12	20	0.00014	3000	50	30	15	69
80 FECCL	K 3	16	25	0.00021	1300	55	30	15	69
90 S FECCL	K 4	20	30	0.00039	1100	65	40	15	69
● 90 S FECCL	K 4 D	40	30	0.00078	1100	65	40	15	69
90 L FECCL	K 4	20	30	0.00039	1100	65	40	15	69
● 90 L FECCL	K 4 D	40	30	0.00078	1100	65	40	15	69
100 L FECCL	K 5	40	45	0.00104	900	75	45	20	70
● 100 L FECCL	K 6	60	50	0.00135	900	180	85	25	70
112 MT FECCL	K 5	40	45	0.00104	880	75	45	20	70
112 M FECCL	K 6	60	50	0.00135	880	180	85	25	70
132 S FECCL	K 7	90	55	0.00219	480	200	95	50	70
● 132 S FECCL	K 7 D	180	55	0.00438	480	200	95	50	70
132 M FECCL	K 7	90	55	0.00219	450	200	95	50	70
● 132 M FECCL	K 7 D	180	55	0.00438	480	200	95	50	70
160 MT FECCL	K 7 D	180	55	0.00438	350	200	95	50	70
160 L FECCL	K 8	200	60	0.00408	350	210	100	60	70
● 160 L FECCL	K 8 D	400	60	0.00816	350	210	100	60	70
180 LT FECCL	K 8 D	400	60	0.00816	100	210	100	60	70
200 LT FECCL	K 9 D	600	110	0.01830	80	230	135	75	69
225 ST FECCL	K 9 D	600	110	0.01830	80	230	135	75	69
250 MT FECCL	K 9 D	600	110	0.01830	80	230	135	75	69
280 ST FECCL	K 9 D	600	110	0.01830	80	230	135	75	69
280 MT FECCL	K 9 D	600	110	0.01830	80	230	135	75	69

MOTORI ASINCRONI TRIFASI AUTOFRENANTI CARATTERISTICHE TECNICHE

FRENO IN CORRENTE CONTINUA
SERIE CCL
CON ROTORE A GABBIA
COSTRUZIONE CHIUSA
VENTILAZIONE ESTERNA
A DUE POLARITÀ

2-4 poli - 3000-1500 giri/min - 50 Hz
4-8 poli - 1500-750 giri/min - 50 Hz
4-6 poli - 1500-1000 giri/min - 50 Hz
6-8 poli - 1000-750 giri/min - 50 Hz

ASYNCHRONOUS THREE-PHASE BRAKE MOTORS TECHNICAL FEATURES

DIRECT CURRENT BRAKE
SERIES CCL
WITH SQUIRREL CAGE ROTOR
ENCLOSED CONSTRUCTION
EXTERNAL VENTILATION
WITH DOUBLE POLARITY

2-4 poles - 3000-1500 rpm - 50 Hz
4-8 poles - 1500-750 rpm - 50 Hz
4-6 poles - 1500-1000 rpm - 50 Hz
6-8 poles - 1000-750 rpm - 50 Hz

DREHSTROM- ASYNCHRON- BREMSMOTOREN TECHNISCHE DATEN

MIT GLEICHSTROMBREMSE
SERIE CCL

MIT KÄFIGLÄUFER
GESCHLOSSENE AUSFÜHRUNG
OBERFLÄCHENKÜHLUNG
POLUMSCHALTBAR

2-4 polig - 3000-1500 U/min - 50 Hz
4-8 polig - 1500-750 U/min - 50 Hz
4-6 polig - 1500-1000 U/min - 50 Hz
6-8 polig - 1000-750 U/min - 50 Hz

I motori autofrenanti hanno tolleranza $\pm 6\%$
sulla tensione di alimentazione.

Brake motors have a $\pm 6\%$ tolerance on the
supply voltage.

Die Bremsmotoren haben eine $\pm 6\%$ Toleranz
auf der Speisespannung.

2 / 4 POLI - 3.000 / 1.500 r.p.m. - 50 Hz - 400V

Avvolgimento Unico Dahlander
Dahlander single winding
Dahlander Einfache Wicklung

MOTOR	Potenza Power Leistung KW		Velocità Speed Drehzahl r.p.m.		Corrente Rated Current Nennstrom Amp @ 400 V	
	Poli - Poles Polig 2 4	Poli - Poles Polig 2 4	Poli - Poles Polig 2 4	Poli - Poles Polig 2 4	Poli - Poles Polig 2 4	Poli - Poles Polig 2 4
63 FECCL	0.22	0.15	2690	1340	0.61	0.55
71 FECCL	0.3	0.22	2760	1350	0.5	0.71
71 FECCL	0.45	0.3	2790	1370	1.1	0.97
80 FECCL	0.55	0.45	2820	1380	1.34	1.26
80 FECCL	0.75	0.6	2830	1410	1.8	1.7
90 S FECCL	1.25	0.95	2830	1380	2.9	2.5
90 L FECCL	1.7	1.32	2840	1400	3.9	3.3
100 L FECCL	2.4	1.84	2840	1400	5.5	4.2
100 L FECCL	3.3	2.6	2850	1420	7.5	5.7
112 MT FECCL	4.5	4	2870	1420	9.9	7.9
132 S FECCL	6	5	2870	1440	13.1	10.2
132 M FECCL	8	6.6	2875	1440	16.8	13.2
160 MT FECCL	11	9	2920	1450	22	18.5
160 L FECCL	15	12	2920	1450	29	25
180 MT FECCL	18.5	15	2930	1460	35	30
180 LT FECCL	22	18.5	2940	1460	42	36
200 LT FECCL	30	22	2940	1460	56	41
225 ST FECCL	37	30	2945	1460	68	56
225 MT FECCL	45	37	2945	1470	83	68
250 MT FECCL	55	45	2950	1470	99	84
280 ST FECCL	66	55	2960	1480	119	99
280 MT FECCL	85	70	2960	1480	152	124

4 / 6 POLI - 1.500 / 1.000 r.p.m. - 50 Hz - 400V

Doppia polarità, avvolgimento separato
Double polarity two separate windings
polumschaltbar - Zwei getrennte Wicklungen

MOTOR	Potenza Power Leistung KW		Velocità Speed Drehzahl r.p.m.		Corrente Rated Current Nennstrom Amp @ 400 V	
	Poli - Poles Polig 4 6	Poli - Poles Polig 4 6	Poli - Poles Polig 4 6	Poli - Poles Polig 4 6	Poli - Poles Polig 4 6	Poli - Poles Polig 4 6
71 FECCL	0.22	0.15	1400	900	0.87	0.71
80 FECCL	0.30	0.22	1400	900	1.07	0.87
80 FECCL	0.45	0.3	1400	900	1.67	1.24
90 S FECCL	0.66	0.45	1400	900	2.45	2
90 L FECCL	0.88	0.60	1380	890	3.17	2.5
100 L FECCL	1.32	0.88	1420	940	3.43	3
100 L FECCL	1.76	1.2	1430	945	4.43	3.7
112 MT FECCL	2.2	1.5	1430	940	5.44	4.8
132 S FECCL	3.3	2.2	1430	940	7.36	5.5
132 M FECCL	4.5	3	1450	950	10	7.4
160 MT FECCL	6.6	4.5	1440	955	13.5	10.3
160 L FECCL	8.8	6	1450	955	17.8	13.5
180 MT FECCL	11	7.5	1450	955	22.3	16.9
180 LT FECCL	15	8.8	1460	970	29	19.4
200 LT FECCL	18.5	12.5	1460	970	38.8	29
200 LT FECCL	22	15	1460	975	45.6	33.9
225 ST FECCL	26	18.5	1460	975	52.6	40.8
225 MT FECCL	30	22	1460	975	60.7	48.5
250 MT FECCL	37	26	1470	980	73.2	55.9
280 ST FECCL	50	37	1470	980	95.5	77.7
280 MT FECCL	63	45	1480	985	118	93.4

4 / 8 POLI - 1.500 / 750 r.p.m. - 50 Hz - 400V

Avvolgimento Unico Dahlander
Dahlander single winding
Dahlander Einfache Wicklung

MOTOR	Potenza Power Leistung KW		Velocità Speed Drehzahl r.p.m.		Corrente Rated Current Nennstrom Amp @ 400 V	
	Poli - Poles Polig 4 8	Poli - Poles Polig 4 8	Poli - Poles Polig 4 8	Poli - Poles Polig 4 8	Poli - Poles Polig 4 8	Poli - Poles Polig 4 8
71 FECCL	0.18	0.11	1330	660	0.74	0.73
80 FECCL	0.25	0.15	1350	680	0.84	0.82
80 FECCL	0.45	0.25	1360	680	1.24	1.16
90 S FECCL	0.55	0.3	1400	690	1.43	1.03
90 L FECCL	0.80	0.45	1400	695	2.08	1.95
100 L FECCL	1.25	0.6	1400	700	3.19	2.67
100 L FECCL	1.76	0.88	1400	700	4.37	3.78
112 MT FECCL	2.2	1.5	1435	700	5.17	4.98
132 S FECCL	3.3	2.2	1435	700	7.65	6.58
132 M FECCL	4.5	3	1440	705	9.67	8.16
160 MT FECCL	5.5	4	1440	710	12	10.9
160 M FECCL	7.5	5	1445	710	14.9	11.7
160 L FECCL	10	7	1450	715	19.1	15.8
180 LT FECCL	15	9.5	1450	715	27.7	20.4
200 LT FECCL	22	15	1460	720	40.1	34.5
225 ST FECCL	26	18.5	1460	720	47.4	44.4
225 MT FECCL	30	22	1460	720	54.1	52.2
250 MT FECCL	37	30	1470	730	66.8	60.9
280 ST FECCL	48	37	1470	730	84.7	76.2
280 MT FECCL	60	45	1480	740	105	91.6

6 / 8 POLI - 1.000 / 750 r.p.m. - 50 Hz - 400V

Doppia polarità, avvolgimento separato
Double polarity two separate windings
polumschaltbar - Zwei getrennte Wicklungen

MOTOR	Potenza Power Leistung KW		Velocità Speed Drehzahl r.p.m.		Corrente Rated Current Nennstrom Amp @ 400 V	
	Poli - Poles Polig 6 8	Poli - Poles Polig 6 8	Poli - Poles Polig 6 8	Poli - Poles Polig 6 8	Poli - Poles Polig 6 8	Poli - Poles Polig 6 8
71 FECCL	0.11	0.075	880	670	0.58	0.55
80 FECCL	0.18	0.11	880	670	0.86	0.67
80 FECCL	0.25	0.18	880	670	1.05	0.92
90 S FECCL	0.37	0.25	880	680	1.28	1.11
90 L FECCL	0.55	0.37	890	680	1.70	1.43
100 L FECCL	0.75	0.55	900	690	2.22	1.85
100 L FECCL	1.03	0.75	940	690	2.97	2.38
112 MT FECCL	1.25	0.95	940	690	3.53	3.26
132 S FECCL	2.2	1.5	940	700	6.06	4.84
132 M FECCL	3	1.85	950	705	8.15	5.7
160 MT FECCL	3.7	2.6	950	705	9.26	7.6
160 M FECCL	4.5	3.3	955	710	10.6	9.2
160 L FECCL	6	4.5	960	710	13.7	12
180 MT FECCL	7.5	5.5	960	710	16.1	14.4
180 LT FECCL	9.5	7.5	960	715	20.4	19.1
200 LT FECCL	12	8.8	970	715	27.1	24
200 LT FECCL	15	11	970	715	32.7	28.7
225 MT FECCL	18.5	14	975	720	38.5	31.9
250 MT FECCL	22	16	980	720	44.6	36
280 ST FECCL	30	22	980	730	59.5	46.5
280 MT FECCL	40	30	985	730	78.3	63.4

**MOTORI
ASINCRONI
TRIFASI
AUTOFRENANTI
CARATTERISTICHE TECNICHE
CUSCINETTI**

FRENO IN CORRENTE CONTINUA
SERIE CCL
CON ROTORE A GABBIA
COSTRUZIONE CHIUSA
VENTILAZIONE ESTERNA
A DUE POLARITA'
2-8 poli - 3000-750 giri/min - 50 Hz

**ASYNCHRONOUS
THREE-PHASE
BRAKE MOTORS
TECHNICAL FEATURES
BEARINGS**

DIRECT CURRENT BRAKE
SERIES CCL
WITH SQUIRREL CAGE ROTOR
ENCLOSED CONSTRUCTION
EXTERNAL VENTILATION
WITH DOUBLE POLARITY
2-8 poles - 3000-750 U/min - 50 Hz

**DREHSTROM-
ASYNCHRON-
BREMSMOTOREN
TECHNISCHE DATEN
LAGER**

MIT GLEICHSTROMBREMSE
SERIE CCL
MIT KÄFIGLÄUFER
GESCHLOSSENE AUSFÜHRUNG
OBERFLÄCHENKÜHLUNG
POLUMSCHALTBAR
2-8 polig - 3000-750 U/min - 50 Hz

CARICHI ASSIALI PER CUSCINETTI

Carico assiale massimo in kg oltre il peso del rotore

AXIAL LOADS ON BEARINGS
Max. axial load in kg. beyond rotor weight

MAXIMAL ZULÄSSIGE
AXIALBELASTUNG DER LAGER
über dem Läufergewicht (in kg)

2 / 8 POLI - 3.000 / 750 r.p.m. - 50 Hz - 400V Doppia polarità, avvolgimento separato Double polarity two separate windings polumschaltbar - Zwei getrennte Wicklungen						
	Potenza Power Leistung KW		Velocità Speed Drehzahl r.p.m.		Corrente Rated Current Nennstrom Amp @ 400 V	
MOTOR	Poli Poles Polig 8		Poli Poles Polig 8		Poli Poles Polig 8	
71 FECCL	0.25	0.06	2690	650	0.75	0.75
80 FECCL	0.37	0.08	2745	660	1.08	0.8
80 FECCL	0.55	0.11	2750	670	1.52	1
90 S FECCL	0.75	0.18	2780	670	2.05	1.32
90 L FECCL	1.1	0.3	2790	680	2.97	1.91
100 L FECCL	1.5	0.37	2800	700	3.76	2.08
100 L FECCL	2.2	0.55	2800	710	5.37	2.92
112 MT FECCL	2.6	0.75	2840	710	6.01	3.35
112 M FECCL	3	0.9	2830	690	6.91	3.87
132 S FECCL	3.7	1.1	2880	700	7.95	4.73
132 M FECCL	5.5	1.5	2900	700	11.5	6.23
160 M FECCL	7.5	2.2	2900	705	15.6	7.78
160 L FECCL	9.5	3	2920	710	19.2	10.6
180 MT FECCL	11	3.7	2920	710	22	12.9
180 LT FECCL	15	4.5	2920	720	28	17.3
200 LT FECCL	18.5	5.5	2920	720	36.2	17.7
225 ST FECCL	22	7.5	2935	720	44.5	23.2
225 MT FECCL	26	8.8	2940	720	51.4	26.8
250 MT FECCL	30	11	2930	720	58.6	30.3
280 ST FECCL	45	18.5	2950	720	85	48.2
280 MT FECCL	55	22	2960	730	102	55.8

CUSCINETTI - BEARINGS - LAGER		
MOTORI 2 ÷ 8 Motor type Motortype	Cuscinetto lato accoppiamento Bearing coupling side Lagertype A-seite	Cuscinetto lato opposto accoppiamento Bearing opposite coupling side Lagertype B-seite
63 FECCL	6202-2Z	6202-2Z
71 FECCL	6203-2Z	6203-2Z
80 FECCL	6204-2Z	6204-2Z
90 S FECCL	6205-2Z	6205-2Z
90 L FECCL	6205-2Z	6205-2Z
100 L FECCL	6206-2Z	6206-2Z
112 MT FECCL	6206-2Z	6206-2Z
132 S FECCL	6208-2Z	6208-2Z
132 M FECCL	6208-2Z	6208-2Z
160 MT FECCL	6209-2Z	6208-2Z
160 M FECCL	6309-2Z C3	6309-2Z C3
160 L FECCL	6309-2Z C3	6309-2Z C3
180 MT FECCL	6310-2Z C3	6309-2Z C3
180 LT FECCL	6310-2Z C3	6309-2Z C3
200 LT FECCL	6312-2Z C3	6310-2Z C3
225 ST FECCL	6313 C3	6312-2Z C3
225 MT FECCL	6313 C3	6312-2Z C3
250 MT FECCL	6314 C3	6314-2Z C3
280 ST FECCL	6316 C3	6316-2Z C3
280 MT FECCL	6316 C3	6316-2Z C3

CARICHI ASSIALI in Kg. Kg. AXIAL LOADS ON BEARINGS Kg. AXIALBELASTUNG DER LAGER				
MOTORE MOTOR TYPE MOTORTYPE	2 Poli 2 Poles 2 Polig	4 Poli 4 Poles 4 Polig	6 Poli 6 Poles 6 Polig	8 Poli 8 Poles 8 Polig
63 FECCL	18	20		
71 FECCL	20	25	30	35
80 FECCL	25	30	35	40
90 S FECCL	27	35	41	42
90 L FECCL	26	34	40	42
100 L FECCL	55	72	80	92
112 MT FECCL	55	72	80	92
132 S FECCL	80	95	115	125
132 M FECCL	78	90	112	120
160 MT FECCL	100	110	130	140
160 M FECCL	110	140	150	175
160 L FECCL	100	130	140	160
180 MT FECCL	115	140		
180 LT FECCL	105	130	135	160
200 LT FECCL	130	160	180	220
225 ST FECCL		190		245
225 MT FECCL	130	180	210	240
250 MT FECCL	160	200	220	250
280 ST FECCL	165	230	290	300
280 MT FECCL	150	210	270	285

I valori indicati si intendono per 20.000 ore di funzionamento a 50 Hz per accoppiamento diretto con direzione del carico fissa, assenza di urti o vibrazioni ai cuscinetti.

The indicated values are specified for 20.000 working hours at 50 Hz cycles for direct coupling with fixed direction of load and without any shocks or vibrations on the bearings.

Die angegebenen Werte gelten für 20.000 Betriebsstunden bei 50 Hz bei Direktkupplung, fester Lastausrichtung und stoss- bzw. schwingungsarmer Lagerung.

I motori autofrenanti hanno tolleranza $\pm 6\%$ sulla tensione di alimentazione.

Brake motors have a $\pm 6\%$ tolerance on the supply voltage.

Die Bremsmotoren haben eine $\pm 6\%$ Toleranz auf der Speisespannung.

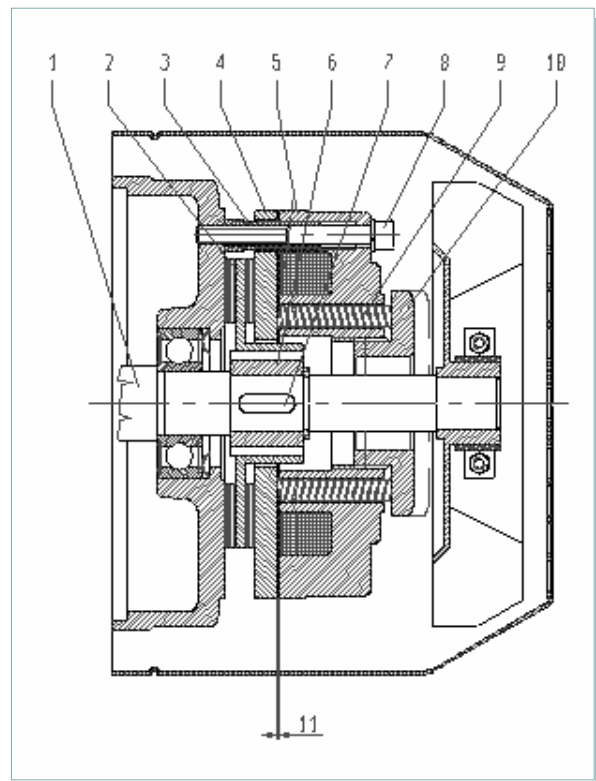
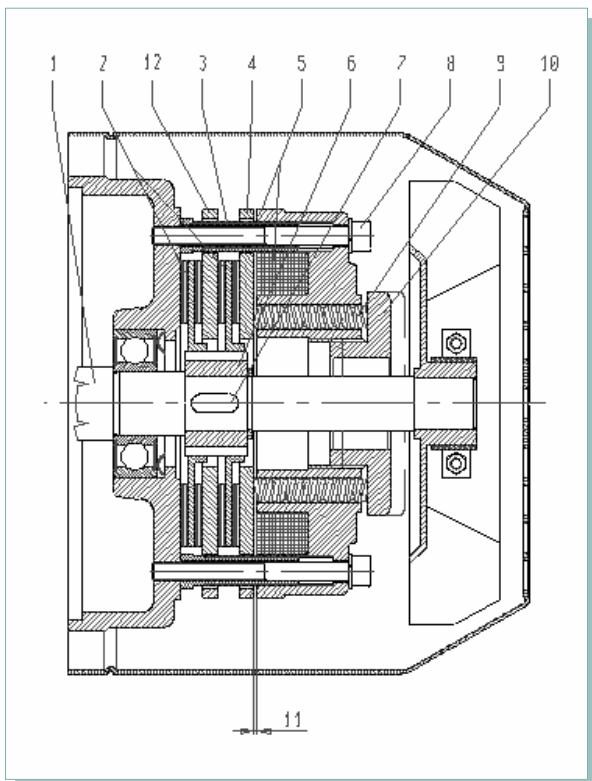

FRENO ELETTROMAGNETICO IN CORRENTE CONTINUA SERIE CCL

PRINCIPALI CARATTERISTICHE

ELECTROMAGNETIC DIRECT CURRENT BRAKE SERIES CCL

MAIN SPECIFICATIONS

ELEKTROMAGNETISCHE GLEICHSTROMBREMSE SERIE CCL

HAUPTEIGENSCHAFTEN

PRINCIPIO DI FUNZIONAMENTO

Il freno a corrente continua viene alimentato tramite un circuito elettronico con ponte a diodi raddrizzatore situato all'interno della coprimorsettiere. Alimentando l'elettromagnete (5) l'ancora mobile (4) viene attratta verso lo stesso caricando le molle di coppia (9) questo permette al disco (2) provvisto di guarnizione di attrito montato sul mozzo scanalato (6) di girare solidale a mezzo linguetta (7) con l'albero motore (1). Togliendo l'alimentazione l'ancora mobile (4) spinta dalle molle di coppia (9) preme sulla superficie di attrito del disco (2) causando l'arresto.

REGOLAZIONE DEL TRAFERRO.

Il traferro (11) è la distanza fra l'elettromagnete (5) e l'ancora mobile (9). Controllare periodicamente il traferro poiché per l'usura della guarnizione di attrito (2) esso tende ad aumentare. Per riportare il traferro al valore iniziale si agisce sui registri (3) dopo aver allentato le viti (8). Per regolare la coppia frenante si deve intervenire sulla ghiera (10) la quale agisce sulle molle di coppia (9). Per informazioni sulle misure di regolazione del traferro contattare il nostro ufficio tecnico.

OPERATING PRINCIPLE

The direct current brake is fed by means of an electronic circuit with diode bridge (rectifier) situated inside the terminal-box. When feeding the electromagnet (5), the movable anchor (4) is attracted towards the same, thus loading the braking torque springs (9) and allowing the disk (2), equipped with friction packing and fitted on the groover hub (6) to turn solidary the motor shaft (1) by means of a key (7). By interrupting the feeding, the movable anchor (4), pushed by the braking torque springs (9), exerts a pressure upon the friction surface of the disk (2), thus causing its stopping.

ADJUSTMENT OF THE AIR GAP.

The air gap (11) is the distance between the electromagnet (5) and the movable anchor (9). The air gap has to be regularly checked, since due to the wear of the friction packing (2) it tends to increase. Act on the brake adjusters (3) after having loosened the screws (8) to bring the air gap to the required value. Act on the ring nut (10) which acts on the braking torque springs (9) to adjust the braking torque. Pls. contact our technical department for information on the air gap adjustment values.

FUNKTIONSWEISE DER BREMSE

Die Gleichstrom - Einflächenscheibendremse wird mittels einer elektrischen Schaltung über einem Brückengleichrichter gespeist, welcher sich im Inneren des Klemmenkastens befindet. Nach Einschalten des Erregerstromes und Speisung der Elektromagneten (5) zieht dieser die bewegliche Ankerscheibe (4) gegen sich an und belastet die Bremsmomentenfedern (9) und die Scheibe (2) welche mit einem Reibbelag ausgestattet ist, und welche auf der Keilnabe (6) angebaut ist, kann sich frei drehen. Die Scheibe ist mit der Antriebswelle (1) über eine Passfeder (7) verbunden. In stromlosen Zustand wird die bewegliche Ankerscheibe (4) durch die Druckkraft der Bremsmomentenfedern (9) auf die Reibfläche der Scheibe (2) gepresst und bewirkt so die Abbremsung der rotierenden Bewegung.

EINSTELLUNG DES LUFTSPALTS

Der Luftspalt (11) ist der Abstand zwischen Elektromagnet (5) und beweglicher Ankerscheibe (9). Es empfiehlt sich die Einstellung des Luftspalts regelmäßig zu überprüfen, da lange Laufzeiten oder extrem starke Belastungen eine Abnutzung der Reibbeläge (2) der Bremscheibe zur Folge haben, wodurch sich der Luftspalt vergrößert. Um den Luftspalt wieder auf den erforderlichen Wert zu bringen, muß der Abstand durch Bewirken auf den Reglern (3) nachgestellt werden, nachdem die Schrauben (8) gelockert worden sind. Um das Bremsmoment einzustellen muß man auf die Nutmutter (10) bewirken, welche auf die Bremsmomentenfedern einwirkt (9). Bitte wenden Sie sich an unsere Technische Abteilung für Angaben bez. die Werte der Luftspalteinstellung.

**MOTORI
ASINCRONI
TRIFASI
AUTOFRENANTI
ALIMENTAZIONE FRENO
SBLOCCO MANUALE A LEVA**

FRENO IN CORRENTE CONTINUA
SERIE CCL
CON ROTORE A GABBIA
COSTRUZIONE CHIUSA
VENTILAZIONE ESTERNA

**ASYNCHRONOUS
THREE-PHASE
BRAKE MOTORS
BRAKE FEEDING
HANDRELEASE WITH LEVER**

DIRECT CURRENT BRAKE
SERIES CCL
WITH SQUIRREL CAGE ROTOR
ENCLOSED CONSTRUCTION
EXTERNAL VENTILATION

**DREHSTROM-
ASYNCHRON
BREMSMOTOREN
SPEISUNG DER BREMSE
HANDLÜFTUNG MIT HEBEL**

MIT GLEICHSTROMBREMSE
SERIE CCL
MIT HÖHEREM BREMSMOMENT
GESCHLOSSENE AUSFÜHRUNG
OBERFLÄCHENKÜHLUNG

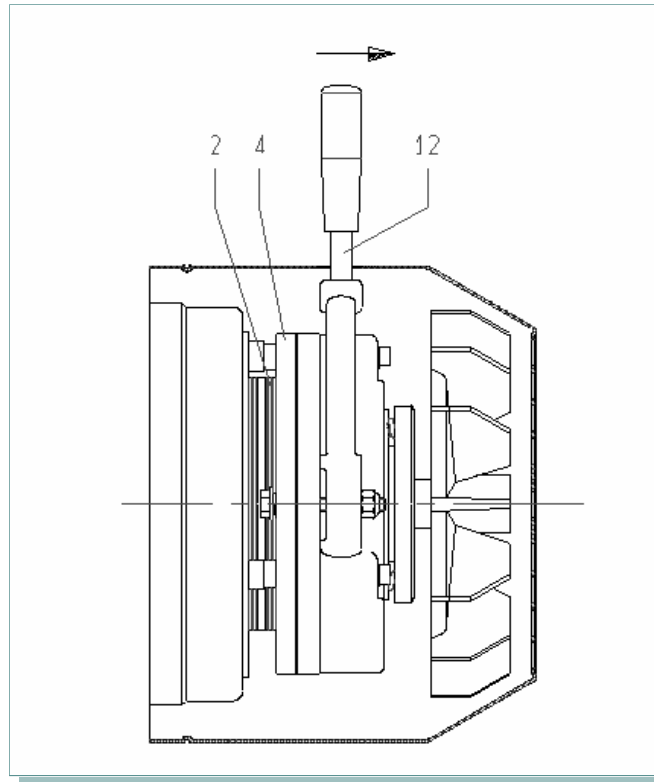

SBLOCCO MANUALE A LEVA - HANDRELEASE WITH LEVER - HANDLÜFTUNG MIT HEBEL

A richiesta viene fornito lo sblocco manuale a leva.

Quando viene a mancare la corrente, agendo sulla leva (12) lo sblocco collegato all'ancora mobile (4), vince la pressione delle molle staccando l'ancora mobile dalla guarnizione d'attrito del disco (2) permettendo all'albero motore di girare.

Upon request an handrelease with lever can be supplied.

In case of a current cutoff, acting on the lever (12), the release, connected to the movable anchor (4) overcomes the springs pressure, thus detaching the movable anchor from the disc friction packing (2) allowing the shaft to turn.

Auf Anfrage liefern wir auch Bremsmotoren mit Handlüftung.

Bei Stromausfall kann durch Betätigen des Hebels (12) der mit dem beweglichen Anker verbundenen Handlüftung (4) die Druckkraft der Federn, welche die Ankerscheibe gegen die Bremsscheibe presst, überwunden werden. So wird die Ankerscheibe vom Bremsbelag des Bremsscheibe (2) freigegeben, und die Welle kann sich frei drehen.

MOTORI C FECCL GRANDEZZE 63 ÷ 112

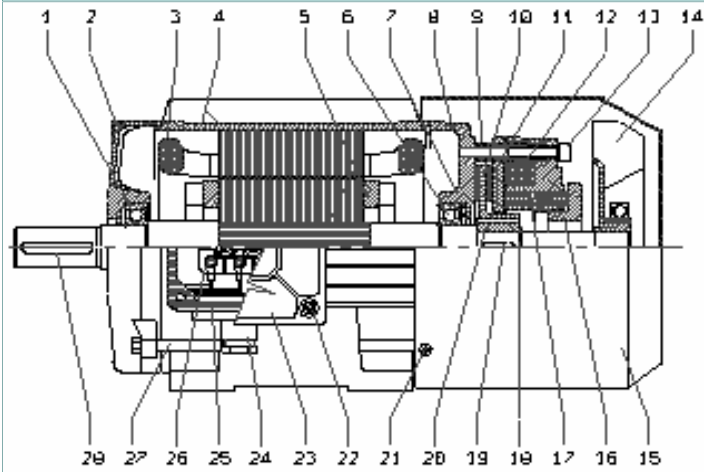

MOTORI C FECCL GRANDEZZE 132 ÷ 280T

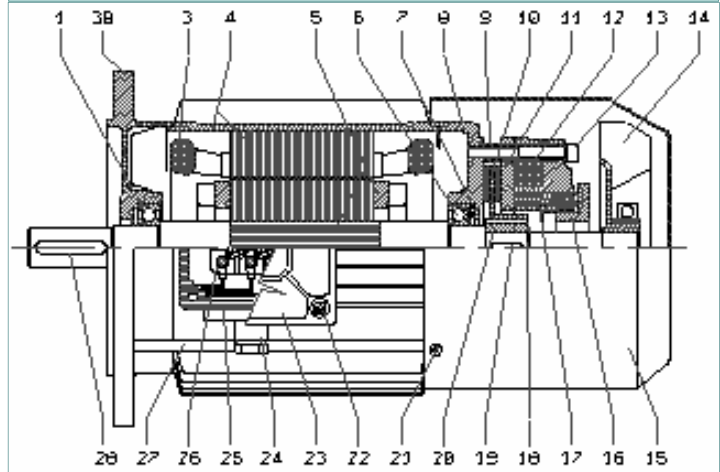

MOTORI FC FECCL GRANDEZZE 63 ÷ 112

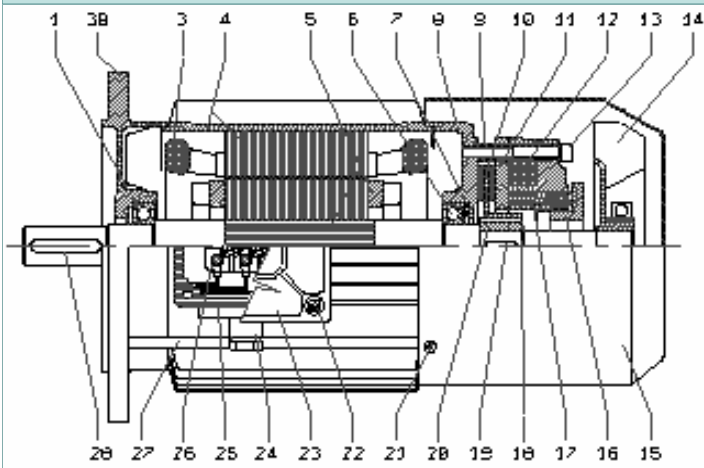

MOTORI FC FECCL GRANDEZZE 132 ÷ 280T

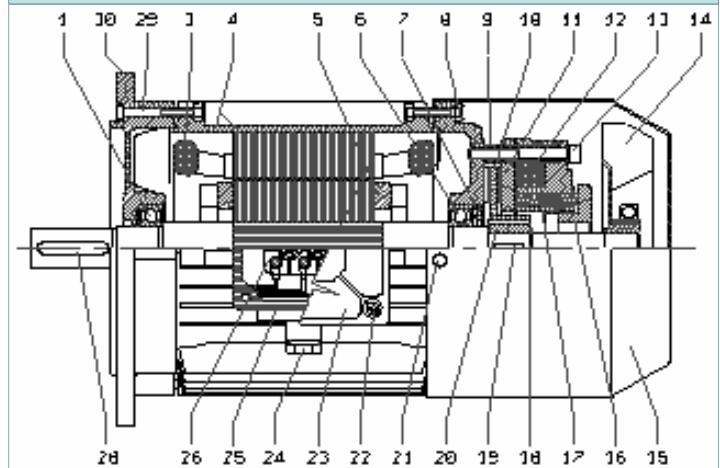

MOTORI ASINCRONI TRIFASI autofrenanti con rotore a gabbia
 Tipo C FECCL UNEL 13113-71 Forma B3 Grandezze 63÷280
 Tipo FC FECCL UNEL 13117-71 Forma B5 Grandezze 63÷280
 Costruzione chiusa - Ventilazione esterna

ASYNCHRONOUS THREE-PHASE BRAKE MOTORS with direct current
 Type C FECCL UNEL 13113-71 Frame B3 Sizes 63÷280
 Type FC FECCL UNEL 13117-71 Frame B5 Sizes 63÷280
 Enclosed construction - External ventilation

DREHSTROM-ASYNCHRON-BREMSMOTOREN mit Gleichstrom-
 bremse - Type C FECCL UNEL 13113-71 Bauform B3 Baugröße
 63÷280 - Type FC FECCL UNEL 13117-71 Bauform B5 Baugröße
 63÷280 - Geschlossene Ausführung - Oberflächenkühlung

PARTI DI RICAMBIO

1. Cuscinetto anteriore
2. Scudo anteriore
3. Avvolgimento
4. Carcassa con pacco statore
5. Albero con rotore
6. Cuscinetto posteriore
7. Molla
8. Scudo posteriore
9. Boccola di registro
10. Disco freno
11. Ancora mobile
12. Elettromagnete con bobina
13. Vite fissaggio freno
14. Ventola di raffreddamento
15. Calotta copriventola
16. Ghiera
17. Molla di coppia
18. Anello Seeger
19. Linguetta lato freno
20. Pignone dentato
21. Vite fissaggio copriventola
22. Vite fissaggio coprimorsettiera
23. Scatola coprimorsettiera
24. Pressacavo
25. Guarnizione
26. Morsettiera
27. Tirante
28. Linguetta lato accoppiamento
29. Vite fissaggio scudo
30. Scudo flangiato

SPARE PARTS

1. Front bearing
2. Front shield
3. Winding
4. Frame with stator package
5. Shaft with rotor
6. Rear bearing
7. Spring
8. Rear shield
9. Adjusting bush
10. Brake disc
11. Moving anchor
12. Electromagnet coil with diode
13. Fixing screws for brake
14. Cooling fan
15. Fan hood
16. Ring nut
17. Spring
18. Seeger ring
19. Key brake side
20. Toothed pinion
21. Fixing screw for fan hood
22. Fixing crew for terminal-box
23. Terminal-box
24. Cable-holder
25. Packing
26. Terminal-block
27. Tie-bolt
28. Coupling side key
29. Fixing screw for shield
30. Flange shield

ERSATZTEILE

1. A-seitiges Lager
2. A-seitiges Lagerschild
3. Wicklung
4. Ständergehäuse mit Paket
5. Welle mit Rotor
6. B-seitiges Lager
7. Feder
8. B-seitiges Lagerschild
9. Eichungsbuchse
10. Bremsscheibe
11. Bewegliche Ankerscheibe
12. Elektromagnet Spule mit Gleichrichter
13. Befestigungsschrauben für Bremse
14. Lüfterflügel
15. Lüfterhaube
16. Nutmutter
17. Feder
18. Seegering
19. Passfeder Bremsseite
20. Verzahnter Ritzel
21. Befestigungsschraube für Lüfterhaube
22. Befestigungsschraube für Klemmenkasten
23. Klemmenkasten
24. PG-Verschraubung
25. Dichtung
26. Klemmbrett
27. Zugbolzen
28. Passfeder A-seite (Antriebsseite)
29. Befestigungsschraube für Lagerschild
30. Flanschlagerschild

**MOTORI
ASINCRONI
TRIFASI
AUTOFRENANTI**
DIMENSIONI D'INGOMBRO in mm.

FRENO IN CORRENTE CONTINUA
SERIE CCL
CON ROTORE A GABBIA
COSTRUZIONE CHIUSA
VENTILAZIONE ESTERNA
Tipo C FECCL - UNEL 13113-71
Forma B3
Grandezze 63÷200

**ASYNCHRONOUS
THREE-PHASE
BRAKE MOTORS**
OVERALL DIMENSIONS in mm.

DIRECT CURRENT BRAKE
SERIES CCL
WITH SQUIRREL CAGE ROTOR
ENCLOSED CONSTRUCTION
EXTERNAL VENTILATION
Type C FECCL - UNEL 13113-71
Frame B3
Sizes 63÷200

**DREHSTROM-
ASYNCHRON-
BREMSMOTOREN**
MASSE in mm.

MIT GLEICHSTROMBREMSE
SERIE CCL
MIT KÄFIGLÄUFER
GESCHLOSSENE AUSFÜHRUNG
OBERFLÄCHENKÜHLUNG
Type C FECCL - UNEL 13113-71
Bauform B3
Baugröße 63÷200

VOGLIATE CONTATTARCI PER TUTTI
I DATI NON ESPRESSI NEL CATALOGO

PLEASE CONTACT US FOR ALL THE DATA
NOT PRINTED IN THIS CATALOGUE

BITTE WENDEN SIE SICH AN UNS FÜR
ALLE ANGABEN WELCHE IM KATALOG
NICHT ENTHALTEN SIND.

I motori autofrenanti hanno tolleranza $\pm 6\%$
sulla tensione di alimentazione.

Brake motors have a $\pm 6\%$ tolerance on the
supply voltage.

Die Bremsmotoren haben eine $\pm 6\%$ Toleranz
auf der Speisespannung.

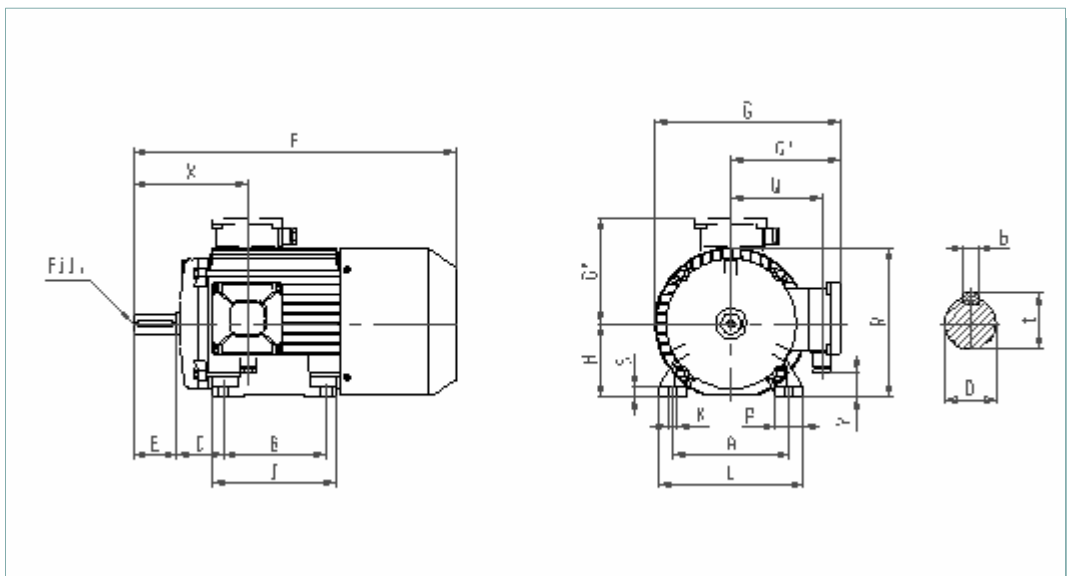

Motor	A	B	C	D	E	F	G	H	K	I	L	P	R	S
NORME IEC	A	B	C	D	E	LC	-	H	K	BB	AB	AA	HC	HA
C63 FECCL	100	80	40	11 j6	23	262	162	63	6	103	128	28	125	7
C71 FECCL	112	90	45	14 j6	30	300	190	71	7	101	137	24	144	10
C80 FECCL	125	100	50	19 j6	40	345	215	80	9	122	155	30	164	10
C90S FECCL	140	100	56	24 j6	50	370	235	90	10	125	175	34	180	12
C90L FECCL	140	125	56	24 j6	50	395	235	90	10	150	175	34	180	12
C100L FECCL	160	140	63	28 j6	60	445	258	100	12	173	198	37	205	14
C112MT FECCL	190	140	70	28 j6	60	445	270	112	12	178	224	38	217	15
C132S FECCL	216	140	89	38 k6	80	625	335	132	13	225	258	50	264	19
C132M FECCL	216	178	89	38 k6	80	625	335	132	13	225	258	50	264	19
C160MT FECCL	254	210	108	42 k6	110	652	362	160	14	250	292	60	290	18
C160M FECCL	254	210	108	42 k6	110	755	410	160	14	332	315	67	325	20
C160L FECCL	254	254	108	42 k6	110	755	410	160	14	332	315	67	325	20
C180MT FECCL	279	241	121	48 k6	110	802	420	180	14	320	350	80	340	22
C180LT FECCL	279	279	121	48 k6	110	802	420	180	14	320	350	80	340	22
C 200LT FECCL	318	305	133	55 m6	100	861	475	200	18	365	395	90	380	24

Motor	G'	X	Y	W	b	t	Pressacavo Cable - holder Verschraubung	Foro filettato Threaded hole Gewindebohrung
NORME IEC	-	-	-	-	F	GA		
C63 FECCL	95	86	18	68	4	12.5	M16x1.5	M 4x0.7
C71 FECCL	115	111	20	88	5	16	M20x1.5	M 5x0.8
C80 FECCL	126	113	30	96	6	21.5	M20x1.5	M 6x1
C90S FECCL	142	134	30	115	8	27	M20x1.5	M 8x1.25
C90L FECCL	142	134	30	115	8	27	M20x1.5	M 8x1.25
C100L FECCL	155	160	35	123	8	31	M25x1.5	M10x1.5
C112MT FECCL	155	160	47	123	8	31	M25x1.5	M10x1.5
C132S FECCL	200	198	50	162	10	41	M25x1.5	M12x1.75
C132M FECCL	200	198	50	162	10	41	M25x1.5	M12x1.75
C160MT FECCL	215	275	50	170	12	45	M32x1.5	M16x2
C160M FECCL	245	345	50	195	12	45	M40x1.5	M16x2
C160L FECCL	245	345	50	195	12	45	M40x1.5	M16x2
C180MT FECCL	245	370	70	195	14	51.5	M40x1.5	M16x2
C180LT FECCL	245	370	70	195	14	51.5	M40x1.5	M16x2
C 200LT FECCL	275	400	100	215	16	59	M40x1.5	M20x2.5

**MOTORI
ASINCRONI
TRIFASI
AUTOFRENANTI**
DIMENSIONI D'INGOMBRO in mm.

FRENO IN CORRENTE CONTINUA
SERIE CCL
CON ROTORE A GABBIA
COSTRUZIONE CHIUSA
VENTILAZIONE ESTERNA
Tipo C FECCL - UNEL 13113-71
Forma B3
Grandezze 225÷280

**ASYNCHRONOUS
THREE-PHASE
BRAKE MOTORS**
OVERALL DIMENSIONS in mm.

DIRECT CURRENT BRAKE
SERIES CCL
WITH SQUIRREL CAGE ROTOR
ENCLOSED CONSTRUCTION
EXTERNAL VENTILATION
Type C FECCL - UNEL 13113-71
Frame B3
Sizes 225÷280

**DREHSTROM-
ASYNCHRON-
BREMSMOTOREN**
MASSE in mm.

MIT GLEICHSTROMBREMSE
SERIE CCL
MIT KÄFIGLÄUFER
GESCHLOSSENE AUSFÜHRUNG
OBERFLÄCHENKÜHLUNG
Type C FECCL - UNEL 13113-71
Bauform B3
Baugröße 225÷280

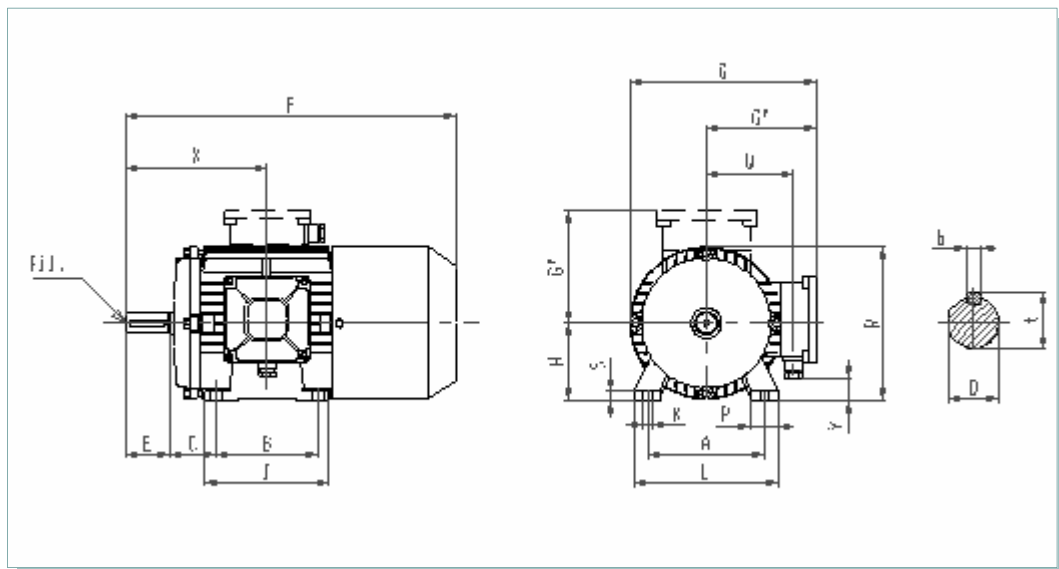

Motor	Poli	A	B	C	D	E	F	G	H	K	I	L	P	R	S
NORME IEC		A	B	C	D	E	LC	-	H ⁺⁰ _{-0.5}	K	BB	AB	AA	HC	HA
C FECCL 225 ST	4-6-8	356	286	149	60 m6	140	948	490	225 ^{-0.5} ₊₀	18	370	436	80	420	30
C FECCL 225 MT	2	356	311	149	55 m6	110	918	490	225 ^{-0.5} ₊₀	18	370	436	80	420	30
C FECCL 225 MT	4-6-8	356	311	149	60 m6	140	948	490	225 ^{-0.5} ₊₀	18	370	436	80	420	30
C FECCL 250 MT	2	406	349	168	60 m6	140	1035	570	250 ^{-0.5} ₊₀	22	410	476	95	480	32
C FECCL 250 MT	4-6-8	406	349	168	65 m6	140	1035	570	250 ^{-0.5} ₊₀	22	410	476	95	480	32
C FECCL 280 ST	2	457	368	190	65 m6	140	1160	650	280 ⁻¹ ₊₀	24	480	534	115	535	35
C FECCL 280 ST	4-6-8	457	368	190	75 m6	140	1160	650	280 ⁻¹ ₊₀	24	480	534	115	535	35
C FECCL 280 MT	2	457	419	190	65 m6	140	1160	650	280 ⁻¹ ₊₀	24	480	534	115	535	35
C FECCL 280 MT	4-6-8	457	419	190	75 m6	140	1160	650	280 ⁻¹ ₊₀	24	480	534	115	535	35

Motor	Poli	G'	X	Y	W	b	t	Pressacavo Cable - holder Verschraubung	Foro filettato Threaded hole Gewindebohrung
NORME IEC		-	-	-	-	F	GA		
C FECCL 225 ST	4-6-8	290	445	115	245	18	64	M50x1.5	M20x2.5
C FECCL 225 MT	2	290	415	115	245	16	59	M50x1.5	M20x2.5
C FECCL 225 MT	4-6-8	290	445	115	245	18	64	M50x1.5	M20x2.5
C FECCL 250 MT	2	330	485	160	270	18	64	M50x1.5	M20x2.5
C FECCL 250 MT	4-6-8	330	485	160	270	18	69	M50x1.5	M20x2.5
C FECCL 280 ST	2	400	540	150	320	18	69	M50x1.5	M20x2.5
C FECCL 280 ST	4-6-8	400	540	150	320	20	79.5	M50x1.5	M20x2.5
C FECCL 280 MT	2	400	540	150	320	18	69	M50x1.5	M20x2.5
C FECCL 280 MT	4-6-8	400	540	150	320	20	79.5	M50x1.5	M20x2.5

VOGLIATE CONTATTARCI PER TUTTI
I DATI NON ESPRESSI NEL CATALOGO

PLEASE CONTACT US FOR ALL THE DATA
NOT PRINTED IN THIS CATALOGUE

BITTE WENDEN SIE SICH AN UNS FÜR
ALLE ANGABEN WELCHE IM KATALOG
NICHT ENTHALTEN SIND.

I motori autofrenanti hanno tolleranza $\pm 6\%$
sulla tensione di alimentazione.

Brake motors have a $\pm 6\%$ tolerance on the
supply voltage.

Die Bremsmotoren haben eine $\pm 6\%$ Toleranz
auf der Speisespannung.

**MOTORI
ASINCRONI
TRIFASI
AUTOFRENANTI**
DIMENSIONI D'INGOMBRO in mm.

FRENO IN CORRENTE CONTINUA
SERIE CCL
CON ROTORE A GABBIA
COSTRUZIONE CHIUSA
VENTILAZIONE ESTERNA
Typo FC FECCL - UNEL 13117-71
Forma B5
Grandezze 63÷200

**ASYNCHRONOUS
THREE-PHASE
BRAKE MOTORS**
OVERALL DIMENSIONS in mm.

DIRECT CURRENT BRAKE
SERIES CCL
WITH SQUIRREL CAGE ROTOR
ENCLOSED CONSTRUCTION
EXTERNAL VENTILATION
Type FC FECCL - UNEL 13117-71
Frame B5
Sizes 63÷200

**DREHSTROM-
ASYNCHRON-
BREMSMOTOREN**
MASSE in mm.

MIT GLEICHSTROMBREMSE
SERIE CCL
MIT KÄFIGLÄUFER
GESCHLOSSENE AUSFÜHRUNG
OBERFLÄCHENKÜHLUNG
Type FC FECCL - UNEL 13117-71
Bauform B5
Baugröße 63÷200

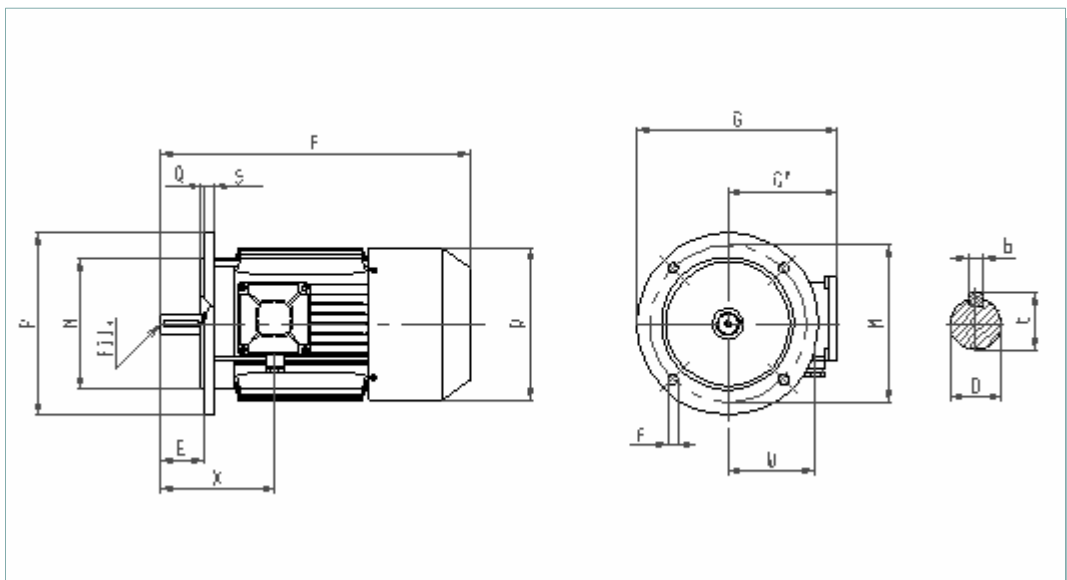

Motor	D	E	F	f	G	M	N	P	Q	R	S	N. fori flangia
NORME IEC	D	E	LC	S	-	M	N	P	T	HC	LA	
FC63 FECCL	11 j6	23	262	9.5	165	115	95 j6	140	3	125	10	4
FC71 FECCL	14 j6	30	300	9.5	195	130	110 j6	160	3.5	148	10	4
FC80 FECCL	19 j6	40	345	11.5	226	165	130 j6	200	3.5	170	12	4
FC90S FECCL	24 j6	50	370	11.5	242	165	130 j6	200	3.5	185	12	4
FC90L FECCL	24 j6	50	395	11.5	242	165	130 j6	200	3.5	185	12	4
FC100L FECCL	28 j6	60	445	14	280	215	180 j6	250	4	210	14	4
FC112MT FECCL	28 j6	60	445	14	280	215	180 j6	250	4	210	14	4
FC132S FECCL	38 k6	80	625	14	350	265	230 j6	300	4	260	14	4
FC132M FECCL	38 k6	80	625	14	350	265	230 j6	300	4	260	14	4
FC160MT FECCL	42 k6	110	652	18	390	300	250 h6	350	5	260	15	4
FC160M FECCL	42 k6	110	755	18	420	300	250 h6	350	5	320	15	4
FC160L FECCL	42 k6	110	755	18	420	300	250 h6	350	5	320	15	4
FC180MT FECCL	48 k6	110	802	18	420	300	250 h6	350	5	320	15	4
FC180LT FECCL	48 k6	110	802	18	420	300	250 h6	350	5	320	15	4
FC 200LT FECCL	55 k6	110	861	18	475	350	300 h6	400	5	360	15	4

Tutti i motori con flangia 4 fori - All the motors with 4 holes on the flange - Alle Motoren mit 4 Flanslöcherbohrung.

Le caratteristiche tecniche, le dimensioni ed ogni altro dato di questo catalogo non sono impegnative. ELECTRO ADDA S.p.A. si riserva il diritto di cambiarle in qualsiasi momento e senza preavviso.

Technical features, dimensions as well as other data in this catalogue are not prescriptive. ELECTRO ADDA S.p.A. reserves itself the right to change them in any time without giving any previous notice.

Die im Katalog aufgeführten Daten, Masse und sonstigen Angaben sind unverbindlich. ELECTRO ADDA S.p.A. behält sich vor, sie zu jeder Zeit und ohne Vorankündigung zu ändern

I motori autofrenanti hanno tolleranza $\pm 6\%$ sulla tensione di alimentazione.

Brake motors have a $\pm 6\%$ tolerance on the supply voltage.

Die Bremsmotoren haben eine $\pm 6\%$ Toleranz auf der Speisespannung.

Motor	G'	X	W	b	t	Pressacavo Cable - holder Verschraubung	Foro filettato Threaded hole Gewindebohrung
NORME IEC	-	-	-	F	GA		
FC63 FECCL	95	86	68	4	12.5	M16x1.5	M4x0.7
FC71 FECCL	115	111	88	5	16	M20x1.5	M5x0.8
FC80 FECCL	126	113	96	6	21.5	M20x1.5	M6x1
FC90S FECCL	142	134	115	8	27	M20x1.5	M8x1.25
FC90L FECCL	142	134	115	8	27	M20x1.5	M8x1.25
FC100L FECCL	155	160	123	8	31	M25x1.5	M10x1.5
FC112MT FECCL	155	160	123	8	31	M25x1.5	M10x1.5
FC132S FECCL	200	198	162	10	41	M25x1.5	M12x1.75
FC132M FECCL	200	198	162	10	41	M25x1.5	M12x1.75
FC160MT FECCL	215	275	170	12	45	M32x1.5	M16x2
FC160M FECCL	245	345	195	12	45	M40x1.5	M16x2
FC160L FECCL	245	345	195	12	45	M40x1.5	M16x2
FC180MT FECCL	245	370	195	14	51.5	M40x1.5	M16x2
FC180LT FECCL	245	370	195	14	51.5	M40x1.5	M16x2
FC 200LT FECCL	275	400	215	16	59	M40x1.5	M20x2.5

**MOTORI
ASINCRONI
TRIFASI
AUTOFRENANTI**
DIMENSIONI D'INGOMBRO in mm.

FRENO IN CORRENTE CONTINUA
SERIE CCL
CON ROTORE A GABBIA
COSTRUZIONE CHIUSA
VENTILAZIONE ESTERNA
 Tipo FC FECCL - UNEL 13117-71
 Forma B5
 Grandezze 225÷280

**ASYNCHRONOUS
THREE-PHASE
BRAKE MOTORS**
OVERALL DIMENSIONS in mm.

DIRECT CURRENT BRAKE
SERIES CCL
WITH SQUIRREL CAGE ROTOR
ENCLOSED CONSTRUCTION
EXTERNAL VENTILATION
 Type FC FECCL - UNEL 13117-71
 Frame B5
 Sizes 225÷280

**DREHSTROM-
ASYNCHRON-
BREMSMOTOREN**
MASSE in mm.

MIT GLEICHSTROMBREMSE
SERIE CCL
MIT KÄFIGLÄUFER
GESCHLOSSENE AUSFÜHRUNG
OBERFLÄCHENKÜHLUNG
 Type FC FECCL - UNEL 13117-71
 Bauform B5
 Baugröße 225÷280

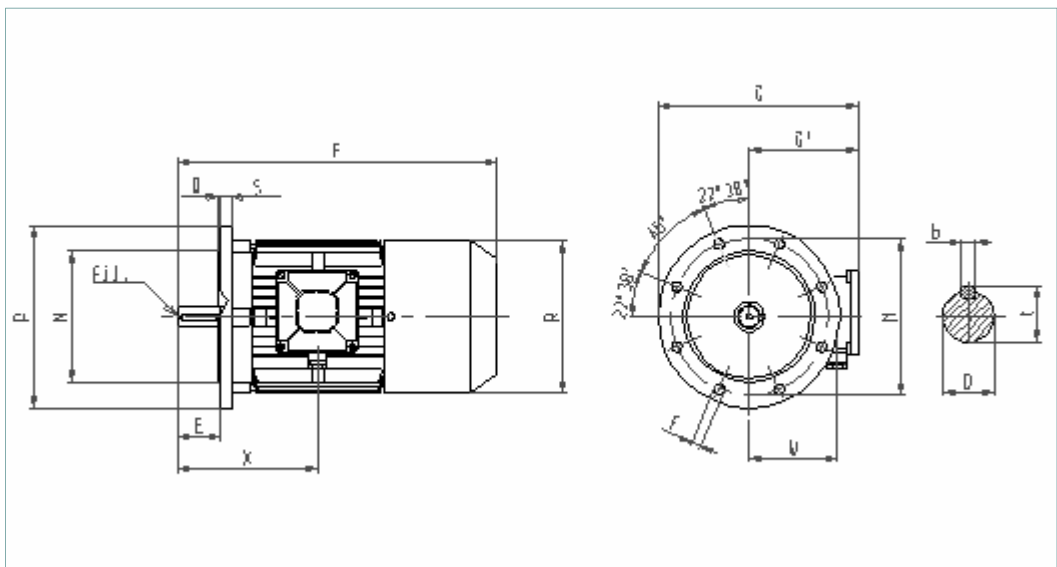

Motor	Poli	D	E	F	f	G	M	N	P	Q	R	S	N. fori flangia
NORME IEC		D	E	LC	S	-	M	N	P	T	HC	LA	
FC FECCL 225 ST	4-6-8	60 m6	140	948	18	515	400	350 h6	450	5	400	16	8
FC FECCL 225 MT	2	55 m6	110	918	18	515	400	350 h6	450	5	400	16	8
FC FECCL 225 MT	4-6-8	60 m6	140	948	18	515	400	350 h6	450	5	400	16	8
FC FECCL 250 MT	2	60 m6	140	1035	18	605	500	450 h6	550	5	450	18	8
FC FECCL 250 MT	4-6-8	65 m6	140	1035	18	605	500	450 h6	550	5	450	18	8
FC FECCL 280 ST	2	65 m6	140	1160	18	675	500	450 h6	550	5	510	18	8
FC FECCL 280 ST	4-6-8	75 m6	140	1160	18	675	500	450 h6	550	5	510	18	8
FC FECCL 280 MT	2	65 m6	140	1160	18	675	500	450 h6	550	5	510	18	8
FC FECCL 280 MT	4-6-8	75 m6	140	1160	18	675	500	450 h6	550	5	510	18	8

Tutti i motori con flangia 8 fori - All the motors with 8 holes on the flange - Alle Motoren mit 8 Flansclöcherbohrung.

VOGLIATE CONTATTARCI PER TUTTI
I DATI NON ESPRESSI NEL CATALOGO

PLEASE CONTACT US FOR ALL THE DATA
NOT PRINTED IN THIS CATALOGUE

BITTE WENDEN SIE SICH AN UNS FÜR
ALLE ANGABEN WELCHE IM KATALOG
NICHT ENTHALTEN SIND.

I motori autofrenanti hanno tolleranza $\pm 6\%$
sulla tensione di alimentazione.

Brake motors have a $\pm 6\%$ tolerance on the
supply voltage.

Die Bremsmotoren haben eine $\pm 6\%$ Toleranz
auf der Speisespannung.

Motor	Poli	G'	X	W	b	t	Pressacavo Cable - holder Verschraubung	Foro filettato Threaded hole Gewindebohrung
NORME IEC		-	-	-	F	GA		
FC FECCL 225 ST	4-6-8	290	445	245	18	64	M50x1.5	M20x2.5
FC FECCL 225 MT	2	290	415	245	16	59	M50x1.5	M20x2.5
FC FECCL 225 MT	4-6-8	290	445	245	18	64	M50x1.5	M20x2.5
FC FECCL 250 MT	2	330	485	270	18	64	M50x1.5	M20x2.5
FC FECCL 250 MT	4-6-8	330	485	270	18	69	M50x1.5	M20x2.5
FC FECCL 280 ST	2	400	540	320	18	69	M50x1.5	M20x2.5
FC FECCL 280 ST	4-6-8	400	540	320	20	79.5	M50x1.5	M20x2.5
FC FECCL 280 MT	2	400	540	320	18	69	M50x1.5	M20x2.5
FC FECCL 280 MT	4-6-8	400	540	320	20	79.5	M50x1.5	M20x2.5

**MOTORI
ASINCRONI
TRIFASI
AUTOFRENANTI**
DIMENSIONI D'INGOMBRO in mm.

SERIE CCL
CON ROTORE A GABBIA
COSTRUZIONE CHIUSA
VENTILAZIONE FORZATA
Tipo C FECCL
Forma B3
Grandezze 71÷200

**ASYNCHRONOUS
THREE-PHASE
BRAKE MOTORS**
OVERALL DIMENSIONS in mm.

SERIES CCL
WITH SQUIRREL CAGE ROTOR
ENCLOSED CONSTRUCTION
FORCED VENTILATION
Type C FECCL
Frame B3
Sizes 71÷200

**DREHSTROM-
ASYNCHRON-
BREMSMOTOREN**
MASSE in mm.

SERIE CCL
MIT KÄFIGLÄUFER
GESCHLOSSENE AUSFÜHRUNG
FREMDLÜFTUNG
Type C FECCL1
Bauform B3
Baugrösse 71÷200

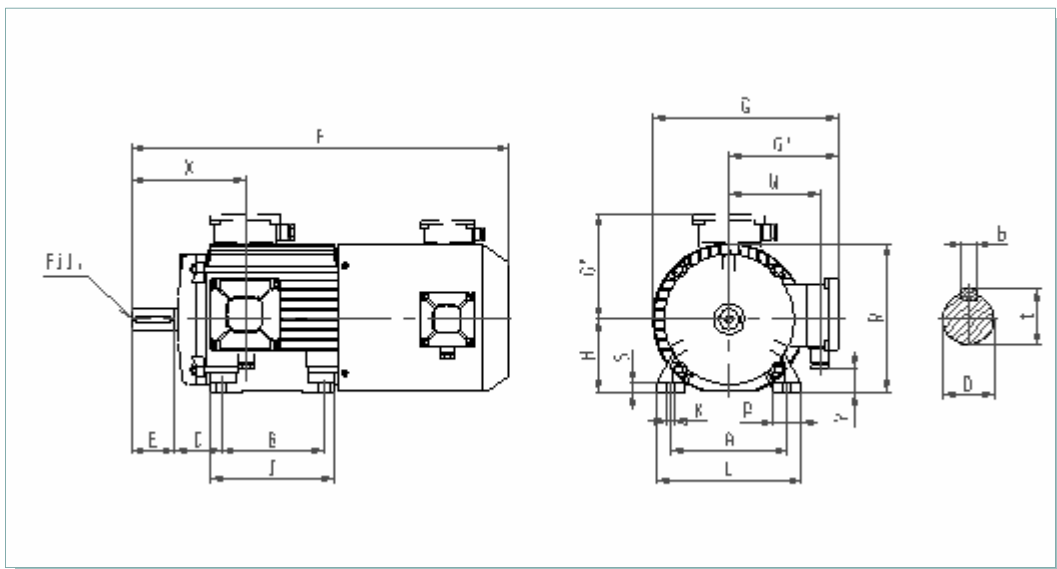

Motor	A	B	C	D	E	F	G	H ^{+0 -0.5}	K	I	L	P	R	S
NORME IEC	A	B	C	D	E	LC	-	H	K	BB	AB	AA	HC	HA
C FECCL 71	112	90	45	14 j6	30	370	190	71	7	101	137	24	144	10
C FECCL 80	125	100	50	19 j6	40	420	215	80	9	122	155	30	164	10
C FECCL 90S	140	100	56	24 j6	50	480	235	90	10	125	175	34	180	12
C FECCL 90L	140	125	56	24 j6	50	505	235	90	10	150	175	34	180	12
C FECCL 100L	160	140	63	28 j6	60	540	258	100	12	173	198	37	205	14
C FECCL 112MT	190	140	70	28 j6	60	540	270	112	12	178	224	38	217	15
C FECCL 132S	216	140	89	38 k6	80	690	335	132	13	225	258	50	264	19
C FECCL 132M	216	178	89	38 k6	80	690	335	132	13	225	258	50	264	19
C FECCL 160MT	254	210	108	42 k6	110	750	362	160	14	250	292	60	290	18
C FECCL 160M	254	210	108	42 k6	110	840	410	160	14	332	315	67	325	20
C FECCL 160L	254	254	108	42 k6	110	840	410	160	14	332	315	67	325	20
C FECCL 180MT	279	241	121	48 k6	110	890	420	180	14	320	350	80	340	22
C FECCL 180LT	279	279	121	48 k6	110	890	420	180	14	320	350	80	340	22
C FECCL 200LT	318	305	133	55 m6	100	950	475	200	18	365	395	90	380	24

Motor	G'	X	Y	W	b	t	Pressacavo motore	Pressacavo motoventilatore	Foro filettato
NORME IEC	-	-	-	-	F	GA			
C FECCL 71	115	111	20	88	5	16	M20x1.5	M20x1.5	M5x0.8
C FECCL 80	126	113	30	96	6	21.5	M20x1.5	M20x1.5	M6x1
C FECCL 90S	142	134	30	115	8	27	M20x1.5	M20x1.5	M8x1.25
C FECCL 90L	142	134	30	115	8	27	M20x1.5	M20x1.5	M8x1.25
C FECCL 100L	155	160	35	123	8	31	M25x1.5	M20x1.5	M10x1.5
C FECCL 112MT	155	160	47	123	8	31	M25x1.5	M20x1.5	M10x1.5
C FECCL 132S	200	198	50	162	10	41	M25x1.5	M20x1.5	M12x1.75
C FECCL 132M	200	198	50	162	10	41	M25x1.5	M20x1.5	M12x1.75
C FECCL 160MT	215	275	50	170	12	45	M32x1.5	M20x1.5	M16x2
C FECCL 160M	245	345	50	195	12	45	M40x1.5	M20x1.5	M16x2
C FECCL 160L	245	345	50	195	12	45	M40x1.5	M20x1.5	M16x2
C FECCL 180MT	245	370	70	195	14	51.5	M40x1.5	M20x1.5	M16x2
C FECCL 180LT	245	370	70	195	14	51.5	M40x1.5	M20x1.5	M16x2
C FECCL 200LT	275	400	100	215	16	59	M40x1.5	M20x1.5	M20x2.5

I motori autofrenanti hanno tolleranza $\pm 6\%$ sulla tensione di alimentazione.

Brake motors have a $\pm 6\%$ tolerance on the supply voltage.

Die Bremsmotoren haben eine $\pm 6\%$ Toleranz auf der Speisespannung.

Pressacavo motore
Pressacavo motoventilatore
Foro filettato

Motor cable-holder
Forced ventilation cable-holder
Threaded hole

Motor Verschraubung
Fremdlüftungsverschraubung
Gewindebohrung

**MOTORI
ASINCRONI
TRIFASI
AUTOFRENANTI**
DIMENSIONI D'INGOMBRO in mm.

SERIE CCL
CON ROTORE A GABBIA
COSTRUZIONE CHIUSA
VENTILAZIONE FORZATA
Tipo C FECCL
Forma B3
Grandezze 225÷280

**ASYNCHRONOUS
THREE-PHASE
BRAKE MOTORS**
OVERALL DIMENSIONS in mm.

SERIES CCL
WITH SQUIRREL CAGE ROTOR
ENCLOSED CONSTRUCTION
FORCED VENTILATION
Type C FECCL
Frame B3
Sizes 225÷280

**DREHSTROM-
ASYNCHRON-
BREMSMOTOREN**
MASSE in mm.

SERIE CCL
MIT KÄFIGLÄUFER
GESCHLOSSENE AUSFÜHRUNG
FREMDLÜFTUNG
Type C FECCL1
Bauform B3
Baugröße 225÷280

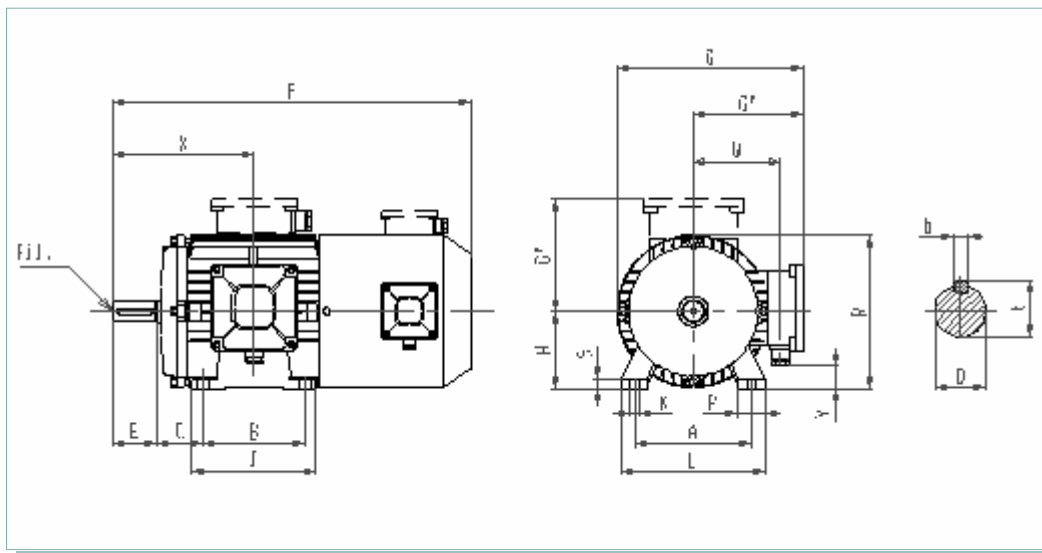

Motor	Poli	A	B	C	D	E	F	G	H	K	I	L	P	R	S
NORME IEC		A	B	C	D	E	LC	-	H ⁺⁰ _{-0.5}	K	BB	AB	AA	HC	HA
C FECCL 225 ST	4-6-8	356	286	149	60 m6	140	1040	490	225 ⁺⁰ _{-0.5}	18	370	436	80	420	30
C FECCL 225 MT	2	356	311	149	55 m6	110	1040	490	225 ⁺⁰ _{-0.5}	18	370	436	80	420	30
C FECCL 225 MT	4-6-8	356	311	149	60 m6	140	1040	490	225 ⁺⁰ _{-0.5}	18	370	436	80	420	30
C FECCL 250 MT	2	406	349	168	60 m6	140	1150	570	250 ⁺⁰ _{-0.5}	22	410	476	95	480	32
C FECCL 250 MT	4-6-8	406	349	168	65 m6	140	1150	570	250 ⁺⁰ ₋₁	22	410	476	95	480	32
C FECCL 280 ST	2	457	368	190	75 m6	140	1400	650	280 ⁺⁰ ₋₁	24	480	534	115	535	35
C FECCL 280 ST	4-6-8	457	368	190	75 m6	140	1400	650	280 ⁺⁰ ₋₁	24	480	534	115	535	35
C FECCL 280 MT	2	457	419	190	65 m6	140	1400	650	280 ⁺⁰ ₋₁	24	480	534	115	535	35
C FECCL 280 MT	4-6-8	457	419	190	75 m6	140	1400	650	280	24	480	534	115	535	35

I motori autofrenanti hanno tolleranza $\pm 6\%$ sulla tensione di alimentazione.

Brake motors have a $\pm 6\%$ tolerance on the supply voltage.

Die Bremsmotoren haben eine $\pm 6\%$ Toleranz auf der Speisespannung.

Pressacavo motore
Pressacavo motoventilatore
Foro filettato

Motor cable-holder
Forced ventilation cable-holder
Threaded hole

Motor Verschraubung
Fremdlüftungsverschraubung
Gewindebohrung

Motor	Poli	G'	X	Y	W	b	t	Pressacavo motore	Pressacavo motoventilatore	Foro filettato
NORME IEC		-	-	-	-	F	GA			
C FECCL 225 ST	4-6-8	290	445	115	245	18	64	M50x1.5	M20x1.5	M20x2.5
C FECCL 225 MT	2	290	415	115	245	16	59	M50x1.5	M20x1.5	M20x2.5
C FECCL 225 MT	4-6-8	290	445	115	245	18	64	M50x1.5	M20x1.5	M20x2.5
C FECCL 250 MT	2	330	485	160	270	18	69	M50x1.5	M20x1.5	M20x2.5
C FECCL 250 MT	4-6-8	330	485	160	270	18	69	M50x1.5	M20x1.5	M20x2.5
C FECCL 280 ST	2	400	540	150	320	20	79.5	M50x1.5	M20x1.5	M20x2.5
C FECCL 280 ST	4-6-8	400	540	150	320	20	79.5	M50x1.5	M20x1.5	M20x2.5
C FECCL 280 MT	2	400	540	150	320	18	69	M50x1.5	M20x1.5	M20x2.5
C FECCL 280 MT	4-6-8	400	540	150	320	20	79.5	M50x1.5	M20x1.5	M20x2.5

**MOTORI
ASINCRONI
TRIFASI
AUTOFRENANTI**
DIMENSIONI D'INGOMBRO in mm.

SERIE CCL
CON ROTORE A GABBIA
COSTRUZIONE CHIUSA
VENTILAZIONE FORZATA
 Tipo FC FECCL
 Forma B5
 Grandezze 71÷200

**ASYNCHRONOUS
THREE-PHASE
BRAKE MOTORS**
OVERALL DIMENSIONS in mm.

SERIES CCL
WITH SQUIRREL CAGE ROTOR
ENCLOSED CONSTRUCTION
FORCED VENTILATION
 Type FC FECCL
 Frame B5
 Sizes 71÷200

**DREHSTROM-
ASYNCHRON-
BREMSMOTOREN**
MASSE in mm.

SERIE CCL
MIT KÄFIGLÄUFER
GESCHLOSSENE AUSFÜHRUNG
FREMDLÜFTUNG
 Type FC FECCL1
 Bauform B5
 Baugrösse 71÷200

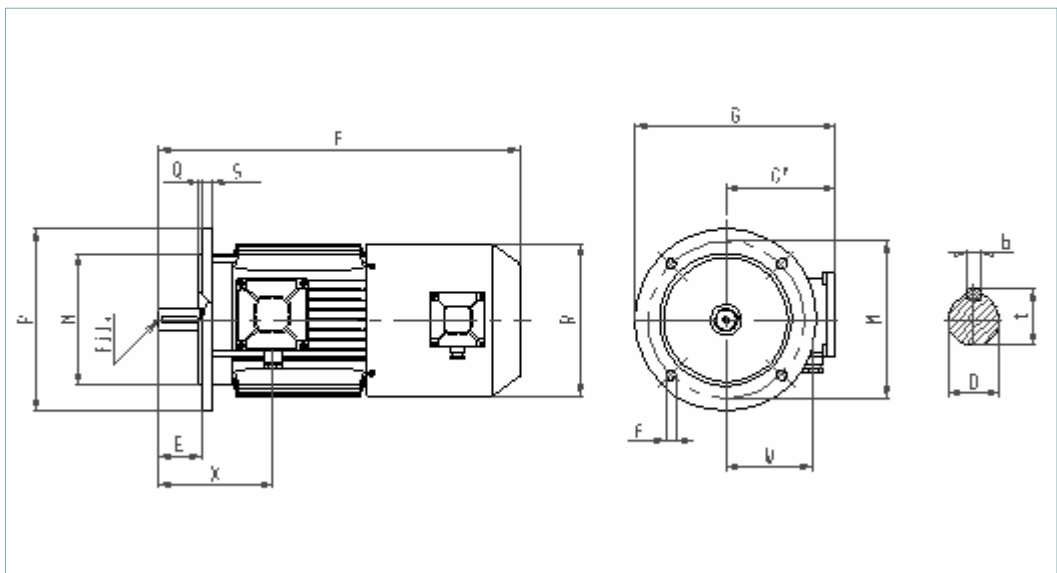

Motor	D	E	F	f	G	M	N	P	Q	R	S	N. fori flangia
NORME IEC	D	E	LC	S	-	M	N	P	T	HC	LA	
FC FECCL 71	14 j6	30	370	9.5	195	130	110 j6	160	3.5	148	10	4
FC FECCL 80	19 j6	40	420	11.5	226	165	130 j6	200	3.5	170	12	4
FC FECCL 90S	24 j6	50	480	11.5	242	165	130 j6	200	3.5	185	12	4
FC FECCL 90L	24 j6	50	505	11.5	242	165	130 j6	200	3.5	185	12	4
FC FECCL 100L	28 j6	60	540	14	280	215	180 j6	250	4	210	14	4
FC FECCL 112MT	28 j6	60	540	14	280	215	180 j6	250	4	210	14	4
FC FECCL 132S	38 k6	80	690	14	350	265	230 j6	300	4	260	14	4
FC FECCL 132M	38 k6	80	690	14	350	265	230 j6	300	4	260	14	4
FC FECCL 160MT	42 k6	110	750	18	390	300	250 h6	350	5	260	15	4
FC FECCL 160M	42 k6	110	840	18	420	300	250 h6	350	5	320	15	4
FC FECCL 160L	42 k6	110	840	18	420	300	250 h6	350	5	320	15	4
FC FECCL 180MT	48 k6	110	890	18	420	300	250 h6	350	5	320	15	4
FC FECCL 180LT	48 k6	110	890	18	420	300	250 h6	350	5	320	15	4
FC FECCL 200LT	55 k6	110	950	18	475	350	300 h6	400	5	360	15	4

I motori autofrenanti hanno tolleranza $\pm 6\%$ sulla tensione di alimentazione.

Brake motors have a $\pm 6\%$ tolerance on the supply voltage.

Die Bremsmotoren haben eine $\pm 6\%$ Toleranz auf der Speisespannung.

Pressacavo motore
Pressacavo motoventilatore
Foro filettato

Motor cable-holder
Forced ventilation cable-holder
Threaded hole

Motor Verschraubung
Fremdlüftungsverschraubung
Gewindebohrung

Tutti i motori con flangia 4 fori - All the motors with 4 holes on the flange - Alle Motoren mit 4 Flanslöcherbohrung.

Motor	G'	X	W	b	t	Pressacavo motore	Pressacavo motoventilatore	Foro filettato
NORME IEC	-	-	-	F	GA			
FC FECCL 71	115	111	88	5	16	M20x1.5	M20x1.5	M5x0.8
FC FECCL 80	126	113	96	6	21.5	M20x1.5	M20x1.5	M6x1
FC FECCL 90S	142	134	115	8	27	M20x1.5	M20x1.5	M8x1.25
FC FECCL 90L	142	134	115	8	27	M20x1.5	M20x1.5	M8x1.25
FC FECCL 100L	155	160	123	8	31	M25x1.5	M20x1.5	M10x1.5
FC FECCL 112MT	155	160	123	8	31	M25x1.5	M20x1.5	M10x1.5
FC FECCL 132S	200	198	162	10	41	M25x1.5	M20x1.5	M12x1.75
FC FECCL 132M	200	198	162	10	41	M25x1.5	M20x1.5	M12x1.75
FC FECCL 160MT	215	275	170	12	45	M32x1.5	M20x1.5	M16x2
FC FECCL 160M	245	345	195	12	45	M40x1.5	M20x1.5	M16x2
FC FECCL 160L	245	345	195	12	45	M40x1.5	M20x1.5	M16x2
FC FECCL 180MT	245	370	195	14	51.5	M40x1.5	M20x1.5	M16x2
FC FECCL 180LT	245	370	195	14	51.5	M40x1.5	M20x1.5	M16x2
FC FECCL 200LT	275	400	215	16	59	M40x1.5	M20x1.5	M20x2.5

**MOTORI
ASINCRONI
TRIFASI
AUTOFRENANTI**
DIMENSIONI D'INGOMBRO in mm.

SERIE CCL
CON ROTORE A GABBIA
COSTRUZIONE CHIUSA
VENTILAZIONE FORZATA
Tipo FC FECCL
Forma B5
Grandezze 225÷280

**ASYNCHRONOUS
THREE-PHASE
BRAKE MOTORS**
OVERALL DIMENSIONS in mm.

SERIES CCL
WITH SQUIREL CAGE ROTOR
ENCLOSED CONSTRUCTION
FORCED VENTILATION
Type FC FECCL
Frame B5
Sizes 225÷280

**DREHSTROM-
ASYNCHRON-
BREMSMOTOREN**
MASSE in mm.

SERIE CCL
MIT KÄFIGLÄUFER
GESCHLOSSENE AUSFÜHRUNG
FREMDLÜFTUNG
Type FC FECCL1
Bauform B5
Baugrösse 225÷280

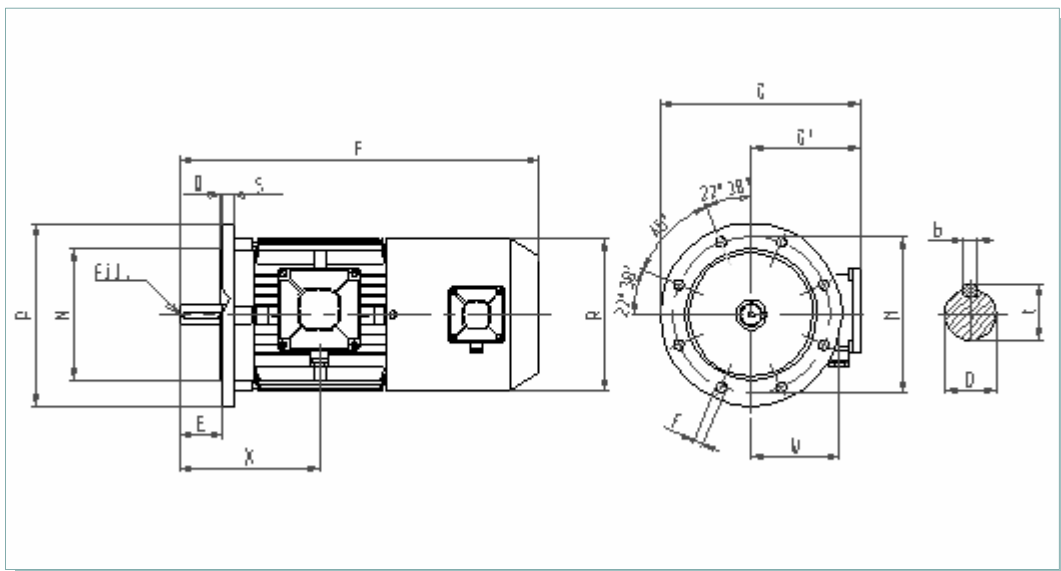

Motor	Poli	D	E	F	f	G	M	N	P	Q	R	S	N. fori flangia
NORME IEC		D	E	LC	S	-	M	N	P	T	HC	LA	
FC FECCL 225ST	4-6-8	60 m6	140	1040	18	515	400	350 h6	450	5	400	16	8
FC FECCL 225MT	2	55 m6	110	1040	18	515	400	350 h6	450	5	400	16	8
FC FECCL 225MT	4-6-8	60 m6	140	1040	18	515	400	350 h6	450	5	400	16	8
FC FECCL 250MT	2	60 m6	140	1150	18	605	500	450 h6	550	5	450	18	8
FC FECCL 250MT	4-6-8	65 m6	140	1150	18	605	500	450 h6	550	5	450	18	8
FC FECCL 280ST	2	65 m6	140	1400	18	675	500	450 h6	550	5	510	18	8
FC FECCL 280ST	4-6-8	75 m6	140	1400	18	675	500	450 h6	550	5	510	18	8
FC FECCL 280MT	2	65 m6	140	1400	18	675	500	450 h6	550	5	510	18	8
FC FECCL 280MT	4-6-8	75 m6	140	1400	18	675	500	450 h6	550	5	510	18	8

Motor	Poli	G'	X	W	b	t	Pressacavo motore	Pressacavo motoventilatore	Foro filettato
NORME IEC		-	-	-	F	GA			
FC FECCL 225ST	4-6-8	290	445	245	18	64	M50x1.5	M20x1.5	M20x2.5
FC FECCL 225MT	2	290	415	245	16	59	M50x1.5	M20x1.5	M20x2.5
FC FECCL 225MT	4-6-8	290	445	245	18	64	M50x1.5	M20x1.5	M20x2.5
FC FECCL 250MT	2	330	485	270	18	64	M50x1.5	M20x1.5	M20x2.5
FC FECCL 250MT	4-6-8	330	485	270	18	69	M50x1.5	M20x1.5	M20x2.5
FC FECCL 280ST	2	400	540	320	20	79.5	M50x1.5	M20x1.5	M20x2.5
FC FECCL 280ST	4-6-8	400	540	320	20	79.5	M50x1.5	M20x1.5	M20x2.5
FC FECCL 280MT	2	400	540	320	18	69	M50x1.5	M20x1.5	M20x2.5
FC FECCL 280MT	4-6-8	400	540	320	20	79.5	M50x1.5	M20x1.5	M20x2.5

I motori autofrenanti hanno tolleranza $\pm 6\%$ sulla tensione di alimentazione.

Brake motors have a $\pm 6\%$ tolerance on the supply voltage.

Die Bremsmotoren haben eine $\pm 6\%$ Toleranz auf der Speisespannung.

Pressacavo motore
Pressacavo motoventilatore
Foro filettato

Motor cable-holder
Forced ventilation cable-holder
Threaded hole

Motor Verschraubung
Fremdlüftungsverschraubung
Gewindebohrung

**MOTORI
ASINCRONI
TRIFASI
AUTOFRENANTI**
DIMENSIONI D'INGOMBRO in mm.

SERIE CCL
CON ROTORE A GABBIA
COSTRUZIONE CHIUSA
VENTILAZIONE FORZATA

Tipo FC FECCL
Forma B14
Grandezze 63÷180

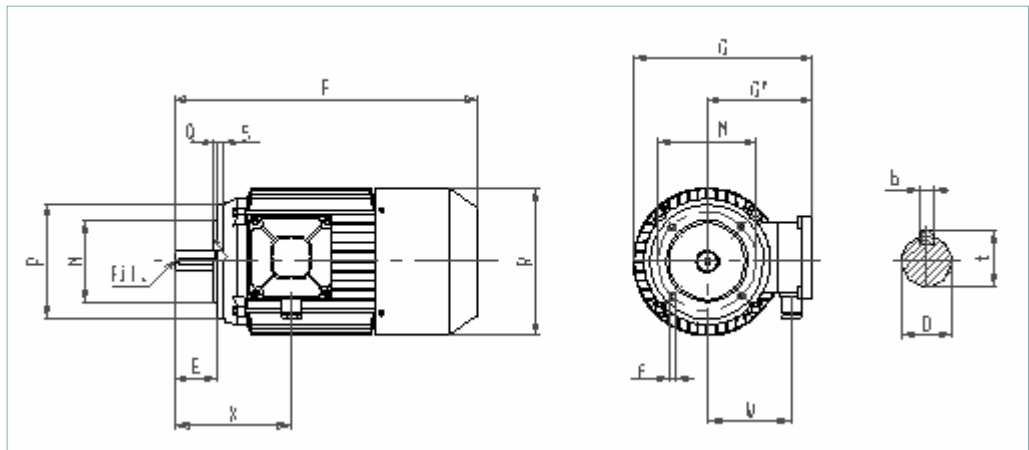

**ASYNCHRONOUS
THREE-PHASE
BRAKE MOTORS**
OVERALL DIMENSIONS in mm.

SERIES CCL
WITH SQUIRREL CAGE ROTOR
ENCLOSED CONSTRUCTION
FORCED VENTILATION

Type FC FECCL
Frame B14
Sizes 63÷180

**DREHSTROM-
ASYNCHRON-
BREMSMOTOREN**
MASSE in mm.

SERIE CCL
MIT KÄFIGLÄUFER
GESCHLOSSENE AUSFÜHRUNG
FREMDLÜFTUNG

Type FC FECCL1
Bauform B14
Baugrösse 63÷180

I motori autofrenanti hanno tolleranza $\pm 6\%$ sulla tensione di alimentazione.

Brake motors have a $\pm 6\%$ tolerance on the supply voltage.

Die Bremsmotoren haben eine $\pm 6\%$ Toleranz auf der Speisespannung.

Tipo	Type	Type
Quota	Dimension	Mass
Pressacavo	Cable-holder	Verschraubung
Foro filettato	Threaded hole	Gewindebohrung

TIPO	D	E	F	f	G	M	N	P	Q	R	S	N. fori flangia
NORME IEC	D	E	L	S	-	M	N	P	T	HC	LA	
FC FECCL 63	11 j6	23	262	M 5	158	75	60 j6	90	2.5	125	8	4
FC FECCL 63	11 j6	23	262	M 6	158	85	70 j6	105	2.5	125	8	4
FC FECCL 63	11 j6	23	262	M 6	158	100	80 j6	120	3	125	8	4
FC FECCL 71	14 j6	30	300	M 6	185	85	70 j6	105	2.5	148	8	4
FC FECCL 71	14 j6	30	300	M 6	185	100	80 j6	120	3	148	8	4
FC FECCL 71	14 j6	30	300	M 8	185	115	95 j6	140	3	148	10	4
FC FECCL 80	19 j6	40	345	M 6	210	85	70 j6	105	2.5	170	8	4
FC FECCL 80	19 j6	40	345	M 6	210	100	80 j6	120	3	170	8	4
FC FECCL 80	19 j6	40	345	M 8	210	115	95 j6	140	3	170	10	4
FC FECCL 80	19 j6	40	345	M 8	210	130	110 j6	160	3.5	170	10	4
FC FECCL 90S	24 j6	50	370	M 8	230	115	95 j6	140	3	185	10	4
FC FECCL 90S	24 j6	50	370	M 8	230	130	110 j6	160	3.5	185	10	4
FC FECCL 90L	24 j6	50	395	M 8	230	115	95 j6	140	3	185	10	4
FC FECCL 90L	24 j6	50	395	M 8	230	130	110 j6	160	3.5	185	10	4
FC FECCL 100L	28 j6	60	445	M 8	255	130	110 j6	160	3.5	210	10	4
FC FECCL 100L	28 j6	60	445	M 10	255	165	130 j6	200	3.5	210	10	4
FC FECCL 112MT	28 j6	60	445	M 8	255	130	110 j6	160	3.5	210	10	4
FC FECCL 112MT	28 j6	60	445	M 10	255	165	130 j6	200	3.5	210	10	4
FC FECCL 132S	38 k6	80	690	M 8	328	130	110 j6	160	3.5	260	15	4
FC FECCL 132S	38 k6	80	690	M 10	328	165	130 j6	200	3.5	260	15	4
FC FECCL 132S	38 k6	80	690	M 12	328	215	180 j6	250	4	260	15	4
FC FECCL 132M	38 k6	80	690	M 8	328	130	110 j6	160	3.5	260	15	4
FC FECCL 132M	38 k6	80	690	M 10	328	165	130 j6	200	3.5	260	15	4
FC FECCL 132M	38 k6	80	690	M 12	328	215	180 j6	250	4	260	15	4
FC FECCL 160MT	42 k6	110	652	M 12	347	215	180 j6	250	4	260	18	4
FC FECCL 160M	42 k6	110	755	M 12	405	215	180 j6	250	4	320	18	4
FC FECCL 160L	42 k6	110	755	M 12	405	215	180 j6	250	4	320	18	4
FC FECCL 180MT	48 k6	110	802	M 12	405	215	180 j6	250	4	320	18	4
FC FECCL 180LT	48 k6	110	802	M 12	405	215	180 j6	250	4	320	18	4

TIPO	G'	X	W	b	t	Pressacavo	Foro filettato
NORME IEC	-	-	-	F	GA		
FC FECCL 63	95	86	68	4	12.5	M 16x1.5	M 4x0.7
FC FECCL 71	115	111	88	5	16	M 20x1.5	M 5x0.8
FC FECCL 80	126	113	96	6	21.5	M 20x1.5	M 6x1
FC FECCL 90S	142	134	115	8	27	M 20x1.5	M 8x1.25
FC FECCL 90L	142	134	115	8	27	M 20x1.5	M 8x1.25
FC FECCL 100L	155	160	123	8	31	M 25x1.5	M 10x1.5
FC FECCL 112MT	155	160	123	8	31	M 25x1.5	M 10x1.5
FC FECCL 132S	200	198	162	10	41	M 25x1.5	M 12x1.75
FC FECCL 132M	200	198	162	10	41	M 25x1.5	M 12x1.75
FC FECCL 160MT	215	275	170	12	45	M 32x1.5	M 16x2
FC FECCL 160M	245	345	195	12	45	M 40x1.5	M 16x2
FC FECCL 160L	245	345	195	12	45	M 40x1.5	M 16x2
FC FECCL 180MT	245	370	195	14	51.5	M 40x1.5	M 16x2
FC FECCL 180LT	245	370	195	14	51.5	M 40x1.5	M 16x2

**MOTORI
ASINCRONI
TRIFASI
AUTOFRENANTI
FORME COSTRUTTIVE**

FRENO IN CORRENTE CONTINUA
SERIE CCL
CON ROTORE A GABBIA
COSTRUZIONE CHIUSA
VENTILAZIONE ESTERNA

**ASYNCHRONOUS
THREE-PHASE
BRAKE MOTORS
MOUNTINGS**





DIRECT CURRENT BRAKE
SERIES CCL
WITH SQUIRREL CAGE ROTOR
ENCLOSED CONSTRUCTION
EXTERNAL VENTILATION

**DREHSTROM-
ASYNCHRON-
BREMSMOTOREN
BAUFORM**

MIT GLEICHSTROMBREMSE
SERIE CCL
GESCHLOSSENE AUSFÜHRUNG
OBERFLÄCHENKÜHLUNG

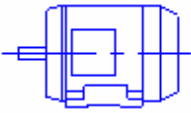
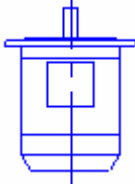
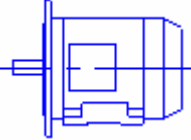
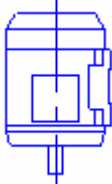
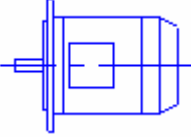
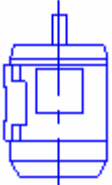
Figura
Picture
Bild

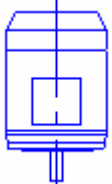
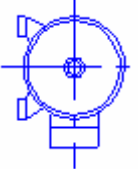
Norme di riferimento
Reference standards
Bezugsnorm

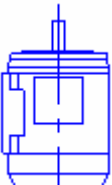
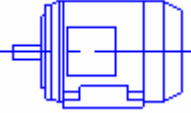
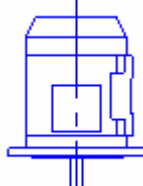
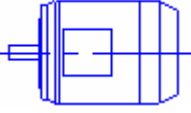
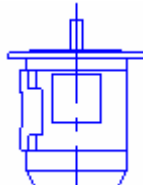
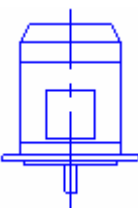
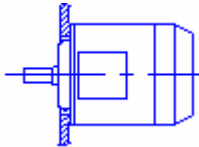
FIGURA	Norme di riferimento		FIGURA	Norme di riferimento		
	CEI 2-14	IEC 34-7		CEI 2-14	IEC 34-7	
		Code I	Code II		Code I	Code II
	B3	IM B3	IM 1001		V3	IM V3 IM 3031
	B3/B5	IM B35	IM 2001		V5	IM V5 IM 1011
	B5	IM B5	IM 3001		V6	IM V6 IM 1031
	B8	IM B8	IM 1071		V18	IM V18 IM 3611
	B6	IM B6	IM 1051		V19	IM V19 IM 3631
	B7	IM B7	IM 1061		V3/V14	IM 2131
	B3/B14	IM B34	IM 2101		V1/V5	IM V15 IM 2011
	B14	IM B14	IM 3601		V3/V6	IM V36 IM 2031
	V1	IM V1	IM 3011		B9	IM B9 IM 9101



www.imaq.it

CERTIFICATO N.
CERTIFICATE N. 9101.ADDA

SI CERTIFICA CHE IL SISTEMA QUALITA' DI
WE HEREBY CERTIFY THAT THE QUALITY SYSTEM OPERATED BY

ELECTRO ADDA SPA
COSTRUZIONI ELETTROMECCANICHE
VIA NAZIONALE 8 - 23883 BEVERATE (LC)

UNITA OPERATIVE
OPERATIVE UNITS

VIA NAZIONALE 8 - 23883 BEVERATE (LC)
VIA S. ANNA 640 - 41100 MODENA (MO)

E' CONFORME ALLA NORMA
IS IN COMPLIANCE WITH THE STANDARD
ISO 9001:2000

PER LE SEGUENTI ATTIVITA'
FOR THE FOLLOWING ACTIVITIES

Progettazione, produzione ed assistenza di macchine elettriche rotanti di bassa tensione per il settore industriale, navale e civile, in particolare: motori asincroni trifasi con rotore a gabbia, autofrenanti con rotore a gabbia, monofasi con rotore a gabbia, antidifiamanti con rotore a gabbia certificati ATEX, a rotore avvolto, convertitori di frequenza, motori ad alta frequenza, motori per seghe circolari, motori per inverter.
Design, manufacturing and service of low voltage electric rotary machines for industrial, naval and civil field, in particular: asynchronous three-phase motors with squirrel cage rotor, brake motors with squirrel cage rotor, single-phase motors with squirrel cage rotor, explosion-proof motors with squirrel cage rotor with ATEX certificate, slip-ring motors, frequency converters, high frequency motors, motors for circular saws, motors for inverter duty

Riferirsi al manuale della qualità per l'applicabilità dei requisiti della norma ISO 9001:2000
Refer to quality manual for details of applications to ISO 9001:2000 requirements

IL PRESENTE CERTIFICATO E' SOGGETTO AL RISPETTO DEL REGOLAMENTO
PER LA CERTIFICAZIONE DEI SISTEMI QUALITA' E DI GESTIONE DELLE AZIENDE
THE USE AND THE VALIDITY OF THE CERTIFICATE SHALL SATISFY THE REQUIREMENTS
OF THE RULES FOR THE CERTIFICATION OF COMPANY QUALITY AND MANAGEMENT SYSTEMS

PRIMA EMISSIONE FIRST ISSUE	EMISSIONE CORRENTE CURRENT ISSUE	DATA SCADENZA EXPIRY DATE
1997-08-04	2007-02-27	2009-11-28

IMQ S.p.A. - VIA QUINTILIANO, 43 - 20138 MILANO

CSQ is a member of



www.iqnet-certification.com

IQNet, the association of the world's first class certification bodies, is the largest provider of management system certification in the world.
IQNet is composed of more than 20 bodies and more than 100 subsidiaries all over the globe.

CSQ è la Federazione Italiana di Organismi di Certificazione dei sistemi di gestione aziendale

CSQ is the Italian Federation of management system Certification Bodies

SINCERT

EA : 19

La validità del presente certificato è subordinata a sorveglianza annuale e al rinnovo completo del Sistema di Qualità non perentoriamente superiore la produzione dell'IMQ
The validity of the certificate is subordinated to annual audit and to re-assessment of the entire Quality System within three years according to IMQ rules



www.csq.it



THE INTERNATIONAL CERTIFICATION NETWORK

CERTIFICATE

IQNet and its partner
CSQ/IMQ-CSQ
hereby certify that the organization

ELECTRO ADDA SPA
COSTRUZIONI ELETTROMECCANICHE

VIA NAZIONALE 8 - 23883 BEVERATE (LC) Italy
VIA S. ANNA 640 - 41100 MODENA (MO) Italy

for the following field of activities

Design, manufacturing and service of low voltage electric rotary machines for industrial, naval and civil field, in particular: asynchronous three-phase motors with squirrel cage rotor, brake motors with squirrel cage rotor, single-phase motors with squirrel cage rotor, explosion-proof motors with squirrel cage rotor with ATEX certificate, slip-ring motors, frequency converters, high frequency motors, motors for circular saws, motors for inverter duty

Refer to quality manual for details of applications to ISO 9001:2000 requirements
has implemented and maintains a

Quality Management System

which fulfills the requirements of the following standard

ISO 9001:2000

Issued on: 2007-02-27

Registration Number:

IT - 34914



René Wasmer
President of IQNET



Gianrenzo Prati
President of CSQ

IQNet partners*:

AENOR Spain AFAQ AFNOR France AIB-Viñçotte International Belgium ANCE Mexico APCER Portugal CSQ Italy CQC China CQM China CQS Czech Republic Cro Cert Croatia DQS Germany DS Denmark ELOT Greece FCAV Brazil FONDONORMA Venezuela HKQAA Hong Kong China ICONTEC Colombia IMNC Mexico Inspecta Certification Finland IRAM Argentina JQA Japan KFG Korea MSZT Hungary Nemko AS Norway NSAI Ireland PCBC Poland QMI Canada Quality Austria Austria RR Russia SAI Global Australia SII Israel SIQ Slovenia SIRIM QAS International Malaysia SQS Switzerland SRAC Romania TEST St Petersburg Russia YUQS Serbia

IQNet is represented in the USA by: AFAQ AFNOR, AIB-Viñçotte International, CSQ, DQS, NSAI Inc., QMI and SAI Global
*The list of IQNet partners is valid at the time of issue of this certificate. Updated information is available under www.iqnet-certification.com

Certificate of Compliance

Document Number: 10000000000000000000
 Revision: 00000000000000000000
 Date: 00/00/0000



Client: ELECTRO ADDA SPA
 VIA NAZIONALE 5
 12081 BIELLA (CUNEO) CN

Description: Motor Constructions for Three Phase Squirrel Cage
 (Detailed technical specifications and standards followed)

Additional Information: (Detailed technical specifications and standards followed)

Model/Type: EA 1004 - Electric Motors
 CSA C22.2 No. 100.05 - Motors and Generators

Additional Information: No Approval Mark

(Detailed technical specifications and standards followed)

Approved for Use: (Detailed technical specifications and standards followed)

Authorized Representative: (Signature and Name)
Authorized Representative: (Signature and Name)

Certificate of Compliance

Document Number: 10000000000000000000
 Revision: 00000000000000000000
 Date: 00/00/0000



Client: Electro Adda S.p.A.
 Via Nazionale 5
 12081 BIELLA (CUNEO) CN

Description: MOTORS
 (Detailed technical specifications and standards followed)

Additional Information: (Detailed technical specifications and standards followed)

Model/Type: EA 1004 - Electric Motors
 CSA C22.2 No. 100.05 - Motors and Generators

Additional Information: No Approval Mark

(Detailed technical specifications and standards followed)

Approved for Use: (Detailed technical specifications and standards followed)

Authorized Representative: (Signature and Name)
Authorized Representative: (Signature and Name)

Certificate of Compliance

Certificate: 1045308 Master Contract: 201661
 Project: 1848621 Date Issued: October 31, 2006
 Issued to: Electro Adda S.p.A.
 Via Nazionale, 8
 Beverate - Brivio, Como 23883
 ITALY
 Attention: Mr Pietro Riva

The products listed below are eligible to bear the CSA Mark shown with adjacent indicators 'C' and 'US'



Issued by: G. Foulem

Authorized by: M.H.J. Hoendervangers

M. Hoendervangers

PRODUCTS

4211-01 - MOTORS AND GENERATORS
 4211-81 - MOTORS AND GENERATORS - Certified for US Standard

Three phase squirrel cage induction motor, permanently connected, component type, class F, 40°C ambient, TEFC, Frame IEC 56-400, max 600Vac, rated out Power 0.09 to 500 kW, 60Hz, 2 to 8 poles, continuous duty. Series RM (regular motors).

Three phase squirrel cage induction motor, permanently connected, component type, class F, 40°C ambient, TEFC, Frame IEC 80-315, max 600Vac, rated out Power 0.75 to 160 kW, 60Hz, 4 poles, continuous duty. Series HEM (High efficiency motors)

Certified as a component motor for use in other equipment where suitability of the combination is to determined by CSA International.

APPLICABLE REQUIREMENTS

CSA Standard C22.2 No. 0-M91 - General Requirements – Canadian Electrical Code, Part II
 CSA Standard C22.2 No. 100-04 - Motors and generators
 UL standard 1004 - Electric Motors

The 'C' and 'US' indicators adjacent to the CSA Mark signify that the product has been evaluated to the applicable CSA and ANSI/UL Standards, for use in Canada and the U.S., respectively. This 'US' indicator includes products eligible to bear the 'NRTL' indicator. NRTL, i.e. National Recognized Testing Laboratory, is a designation granted by the U.S. Occupational Safety and Health Administration (OSHA) to laboratories which have been recognized to perform certification to U.S. Standards.

Supplement to Certificate of Compliance

Certificate: 1045308 Master Contract: 201661

The products listed, including the latest revision described below, are eligible to be marked in accordance with the referenced Certificate.

Product Certification History

Project	Date	Description
1848621	October 31, 2006	Update to report 1045308 to cover the introduction of new components in the Insulation System and the uprate of the Power Supply voltage for motors HEM and RM series.
1045308	November 22, 1999	C/CSA/US on 3 ph squirrel cage induction motors, Series HEM and RM.



DICHIARAZIONE DI CONFORMITA'

IL Produttore :

Electro Adda S.p.A
Costruzioni Elettromeccaniche
Via Nazionale 8 23883 Beverate di Brivio

dichiara che i motori asincroni monofasi e trifasi altezze d'asse 56 + 500
sono realizzati in conformità alle seguenti normative internazionali :

IEC 34 (CEI EN 60034)

ed alle seguenti Direttive Europee :

- **Direttiva Bassa Tensione (LVD) 2006/95/CE**
- **Direttiva Compatibilità Elettromagnetica (EMC) 2004/108/CE**
- **Direttiva sulla limitazione dell'impiego di alcune sostanze pericolose nelle apparecchiature elettriche ed elettroniche (RoHS) 2002/95/CE**

I motori in oggetto sono inoltre conformi alla Direttiva "Macchine" 2006/42/CE, assumendo per questa che il componente motore non può essere messo in servizio prima che la macchina, in cui sarà incorporato, sia stata dichiarata conforme alle disposizioni della Direttiva. Nell'impiego del motore è necessario garantire il rispetto della norma EN 60204-1 e delle istruzioni di sicurezza e di installazione riportate nel manuale d'uso del produttore.

Beverate di Brivio
25/04/2007

Electro Adda S.p.A.
Il C. Delegato/Delegated
"Lecco/Lecco"



COMPLIANCE DECLARATION

The Manufacturer :

Electro Adda S.p.A
Costruzioni Elettromeccaniche
Via Nazionale 8 23883 Beverate di Brivio - Italy

Hereby declares that the asynchronous single-phase and three-phase motors sizes 56 + 500
are carried out in compliance with the following international standards :

IEC 34 (CEI EN 60034)

and to the following European Directives :

- **Low Voltage Directive (LVD) 2006/95/CE**
- **Electromagnetic Compatibility Directive (EMC) 2004/108/EC**
- **Directive on the restriction of the use of certain hazardous substances in electrical and electronic equipment (RoHS) 2002/95/EC**

The captioned motors are also in compliance with the "Machinery Directive" 2006/42/EC, assuming for this, that the motor component may not be put into service before the machine in which it will be assembled, has been declared to be in compliance with the Directive provisions. When operating the motor, it is necessary to assure that the Standard EN 60204-1 and the installation and safety instructions of the manufacturer's operating handbook are observed.

Beverate di Brivio
25/04/2007

Electro Adda S.p.A.
Il C. Delegato/Delegated
"Lecco/Lecco"



KONFORMITÄTSERLÄRUNG

Der Hersteller :

Electro Adda S.p.A
Costruzioni Elettromeccaniche
Via Nazionale 8 23883 Beverate di Brivio - Italien

erklärt dass die Einphasen- und Drehstromasynchronmotoren Achsenhöhe 56 + 500

nach den folgenden internationalen Normen :

IEC 34 (CEI EN 60034)

und den folgenden Europäischen Richtlinien :

- **Niederspannungsrichtlinie (LVD) 2006/95/CE**
- **Richtlinie Elektromagnetische Verträglichkeit (EMV) 2004/108/EG**
- **Richtlinie zur Beschränkung der Verwendung bestimmter gefährlicher Stoffe in elektrischen und elektronischen Geräten (RoHS) 2002/95/EG** verwickelt sind.

Außerdem entsprechen die oben angegebenen Motoren der "Maschinenrichtlinie" 2006/42/EG, wobei wir annehmen dass die Inbetriebnahme vom Bestandteil Motor solange untersagt ist, bis erklärt wird dass die Maschine in die dieser Bestandteil eingebaut wird, den Vorgaben der Maschinenrichtlinie entspricht. Beim Gebrauch vom Motor ist es erforderlich zu gewährleisten dass die Norm EN 60204-1 und die Sicherheits- und Aufstellungsanweisungen beachtet werden, welche in den Betriebsanweisungen vom Hersteller beschrieben sind.

Beverate di Brivio
25/04/2007

Electro Adda S.p.A.
Il C. Delegato/Delegated
"Lecco/Lecco"

ELECTRO ADDA S.P.A.

Via Nazionale 8
Beverate di Brivio (LC)
Tel +39 039 53.20.621
Fax +39 039 53.21.335
www.electroadda.com
info@electroadda.com

Unità locale Modena:
Via S. Anna 640
Modena
Tel +39 059 45.21.32
Fax +39 059 45.21.58
commerciale.modena@electroadda.com

CINEMATIC S.R.L.

Via Padova 20/22
Brescia
Tel +39 030 35.41.171
Fax +39 030 34.94.48
www.cinematicriduttori.it
info@cinematicriduttori.it

ADDA ANTRIEBSTECHNIK GMBH

Max-Planck-Strasse 2
Rödermark
Tel 0049 6074 91.050
Fax 0049 6074 91.0520
info@adda-motoren.de

MACCHINE ELETTRICHE ROTANTI	ELECTRIC ROTARY MACHINES	ROTIERENDE ELEKTRISCHE DREHMASCHINEN
1A Motori asincroni trifasi con rotore a gabbia Costruzione chiusa - Ventilazione esterna Grandezze 63÷315 - Potenze 0.06-200 kW	1A Asynchronous three-phase motors with squirrel cage rotor - Enclosed construction - Externally ventilated Sizes 63 to 315 - Power 0.06 to 200 kW	1A Drehstrom-Asynchronmotoren mit Käfigläufer Geschlossene Ausführung - Oberflächenkühlung Baugröße 63 bis 315 - Leistung 0.06 bis 200 kW
1B Motori asincroni trifasi con rotore a gabbia Costruzione chiusa - Ventilazione esterna Grandezze 355÷500 - Potenze 160-1200 kW	1B Asynchronous three-phase motors with squirrel cage rotor - Enclosed construction - Externally ventilated Sizes 355 to 500 - Power 160 to 1200 kW	1A Drehstrom-Asynchronmotoren mit Käfigläufer Geschlossene Ausführung - Oberflächenkühlung Baugröße 355 bis 500 - Leistung 160 bis 1200 kW
2 CA Motori asincroni trifasi autofrenanti Costruzione chiusa - Ventilazione esterna Con freno elettromagnetico in corrente alternata Grandezze 71÷280 - Potenze 0.18-75 kW	2 CA Asynchronous three-phase brake motors Enclosed construction - Externally ventilated With alternate current electromagnetic brake Sizes 71 to 280 - Power 0.18 to 75 kW	2 CA Drehstrom-Asynchronmotoren mit angebauter Bremsen - Geschlossene Ausführung Oberflächenkühlung - Mit elektromagnetischer Drehstrom - Federdruck - Scheibenbremse Baugröße 71 bis 280 - Leistung 0.18 bis 75 kW
2 CC Motori asincroni trifasi autofrenanti Costruzione chiusa - Ventilazione esterna Con freno elettromagnetico in corrente continua Grandezze 63÷180 - Potenze 0.18-25 kW	2 CC Asynchronous three-phase brake motors Enclosed construction - Externally ventilated With direct current electromagnetic brake Sizes 63 to 180 - Power 0.18 to 25 kW	2 CC Drehstrom-Asynchronmotoren mit angebauter Bremsen - Geschlossene Ausführung - Oberflächenkühlung - Mit elektromagnetischer Gleichstrom - Einflächens - Scheibenbremse Baugröße 63 bis 180 - Leistung 0.18 bis 25 kW
2 CCH Motori asincroni trifasi autofrenanti Costruzione chiusa - Ventilazione esterna Con freno elettromagnetico in corrente continua ad alta coppia Grandezze 63÷112 - Potenze 0.18-5.5 kW	2 CCH Asynchronous three-phase brake motors Enclosed construction - Externally ventilated With direct current electromagnetic brake with high torque Sizes 63 to 112 - Power 0.18 to 5.5 kW	2 CCH Drehstrom-Asynchronmotoren mit angebauter Bremsen - Geschlossene Ausführung - Oberflächenkühlung - Mit elektromagnetischer Gleichstrom - Einflächens - Scheibenbrems mit höherem Bremsmoment Baugröße 63 bis 112 - Leistung 0.18 bis 5.5 kW
2 CCL Motori asincroni trifasi autofrenanti Costruzione chiusa - Ventilazione esterna Con freno elettromagnetico in corrente continua ad alta coppia e bassa rumorosità Grandezze 63÷280 - Potenze 0.18-75 kW	2 CCL Asynchronous three-phase brake motors Enclosed construction - Externally ventilated With direct current electromagnetic brake with high torque and low noise execution Sizes 63 to 280 - Power 0.18 to 75kW	2 CCL Drehstrom-Asynchronmotoren mit angebauter Bremsen - Geschlossene Ausführung - Oberflächenkühlung - Mit elektromagnetischer Gleichstrom - Einflächens - Scheibenbremse mit höherem Bremsmoment und geräuscharmer Ausführung Baugröße 63 bis 280 - Leistung 0.18 bis 75 kW
3 Motori asincroni monofasi con rotore a gabbia Costruzione chiusa - Ventilazione esterna Grandezze 56÷112 - Potenze 0.06-4 kW	3 Asynchronous single-phase motors with squirrel cage rotor Enclosed construction - Externally ventilated Sizes 56 to 112 - Power 0.06 to 4 kW	3 Einphasen-Wechselstrommotoren mit Käfigläufer Geschlossene Ausführung - Oberflächenkühlung Baugröße 56 bis 112 - Leistung 0.06 bis 4 kW
4IIB Motori asincroni trifasi con rotore a gabbia antideflagranti - Serie PE-Ex d Costruzione chiusa - Ventilazione esterna Grandezze 71÷180 - Potenze 0.37-37 kW	4IIB Explosion-proof asynchronous three-phase motors with squirrel cage rotor—Series PE-Ex d Enclosed construction - Externally ventilated Sizes 71 to 180 - Power 0.37 to 37 kW	4IIB Drehstrom-Asynchronmotoren mit Käfigläufer Explosiongeschützt, druckfeste Kapselung Typenreihe PE-Ex d Geschlossene Ausführung - Oberflächenkühlung Baugröße 71 bis 180 - Leistung 0.37 bis 37 kW
4IIC Motori asincroni trifasi con rotore a gabbia antideflagranti - Serie PE-Ex d Ex de Costruzione chiusa - Ventilazione esterna Grandezze 63÷315 - Potenze 0.09-132 kW	4IIC Explosion-proof asynchronous three-phase motors with squirrel cage rotor - Series PE-Ex d Ex de - Enclosed construction Externally ventilated Sizes 63 to 315 - Power 0.09 to 132 kW	4IIC Drehstrom-Asynchronmotoren mit Käfigläufer Explosiongeschützt, druckfeste Kapselung Typenreihe PE-Ex d Ex de Geschlossene Ausführung - Oberflächenkühlung Baugröße 63 bis 315 - Leistung 0.09 bis 132 kW
5 Motori asincroni trifasi con rotore avvolto Costruzione chiusa - Ventilazione esterna Grandezze 100÷560 - Potenze 0.75-560 kW	5 Asynchronous three-phase motors with wound rotor Enclosed construction - Externally ventilated Sizes 100 to 560 - Power 0.75 to 560 kW	5 Drehstrom-Asynchronmotoren mit Schleifringläufer Geschlossene Ausführung - Oberflächenkühlung Baugröße 100 bis 560 - Leistung 0.75 bis 560 kW
6 Motori asincroni trifasi con rotore a gabbia Serie MR azionati da inverter per vie a rulli Grandezze 132÷400 - Potenze 0.83-230 kW	6 Asynchronous three-phase motors with squirrel cage rotor - Series MR supplied by inverter for roller table Sizes 132 to 400 - Power 0.83 to 230 kW	6 Drehstrom-Asynchronmotoren mit Käfigläufer Typenreihe MR - Rollgangmotoren - für Umrichterbetrieb Baugröße 132 bis 400 - Leistung 0.83 bis 230 kW
7 Motori asincroni trifasi - Serie Q Grandezze 280÷560 - Potenze 160-2000 kW	7 Asynchronous three-phase motors - Series Q Sizes 280 to 560 - Power 160 to 2000 kW	7 Drehstrom-Asynchronmotoren - Typenreihe Q Baugröße 280 bis 560 - Leistung 160 bis 2000 kW
8 Motori ad alta efficienza	8 High Efficiency Motors	8 Motoren Mit Höherem Wirkungsgrad
9 Motori asincroni trifasi - Serie MAR Grandezze 63÷355 - Potenze 0.13-365 kW	9 Asynchronous three-phase motors - Series MAR Sizes 63 to 355 - Power 0.13 to 365 kW	9 Drehstrom-Asynchronmotoren - Typenreihe MAR Baugröße 63 bis 355 - Leistung 0.13 bis 365 kW